

276



AM5SE Protection Relay

User Manual V1.6

Acrel Co., LTD

DECLARATION

All rights reserved. No part of this publication may be reproduced, stored in a retrieval system, or transmitted in any form by any means, electronic, mechanical photocopying, recording, or otherwise without prior permission of our company. The violator will bear the dependent legal responsibility.

We reserve all the rights.

We reserve all the rights to revise product specification without notice. Please consult local agent to get the latest information of our products specification.

Table of Contents

1	Instruction	1
1.1	Product overview	1
1.2	Selection guide by application	3
1.3	Relay Selection Table	6
2	Technical Characteristics	7
2.1	Rated Characteristics	7
2.2	Protection characteristics	8
2.3	Environmental characteristics	8
2.4	Product safety	8
2.5	Electromagnetic Compatibility Characteristics	9
3	Use	10
3.1	Front panel	10
3.2	Push buttons	11
3.3	Menu Description	11
3.3.1	Navigation	13
3.3.2	Configuration	15
3.3.3	Parameter	15
3.4	Debug	17
3.5	Record	17
3.6	Communication	18
3.7	Control	21
3.8	Time	21
3.9	Information	22
4	Dimensions and Installation	23
4.1	Dimensions and Cut-out dimensions	23
4.2	Installation procedure	23
5	Wiring	24
5.1	AM5SE rear panel	24
5.2	Typical application	25
6	Product maintenance	27
	Appendix A Setting value	29
	Appendix B Relay Event	164

1 Instruction

1.1 Product overview

The AM5SE relay has the modular design and it can be optimized to almost all type of feeder protection applications in medium voltage distribution systems.

Main characteristic

➤ **Robust hardware**

The AM5SE Protection Relay adopts the 168MHz processor, 16-bit synchronous sampling A/D, 48 points high-speed sampling per cycle, and real-time parallel computing. The relay has sufficient hardware resources and high reliability, with 512K bytes Flash, (192 + 4) K bytes Sram, external 4M bytes NorFlash, external 512K bytes Sram.

➤ **Protection functions**

The AM5SE relay has a modular design and it can be optimized to the line, transformer, distribution transformer, motor, capacitor, bus-bar, PT protection applications in medium voltage distribution systems.

➤ **Rich measuring inputs**

3 phase currents

2 Residual currents

3 phase voltages

1 Residual voltage

20 digital inputs

10 digital outputs

2 programmable 4-20mA DC outputs

Trip and close circuit supervision, which can adapt to 0.25~5A trip-and-close current.

➤ **Communication**

2 RS485 ports

2 Ethernet ports

1 IRIG/B port

1 USB connection for AM5SE setting software

1 RS232 port

Powerful CPU supporting Modbus-RTU/TCP, IEC 60870-5-103, 101

➤ **User-machine interface(UMI)**

Clear LCD display for alarms and events

Programmable functions keys and LEDs

Programmable tripping output matrix

➤ **Logs and Records**

The relay has sequence of event record and disturbance record .

1.2 Selection guide by application

Analogue inputs	AM5SE														
	-F	-T	-M	-C	-MD	-D2	-D3	-TB	-IS	-FE	-FA	-B	-K	-UB	-FD
Input current	8	8	8	8	9	9	9	8	6	8	8	8	8	0	/
Input voltage	6	4	4	4	4	4	4	4	8	6	6	6	6	8	/
Digital	-F	-T	-M	-C	-MD	-D2	-D3	-TB	-IS	-FE	-FA	-B	-K	-UB	-FD
Digital Input	20	20	20	20	20	20	20	20	20	20	20	20	20	20	12
Digital Output	10	10	10	10	10	10	10	10	10	10	10	10	10	10	64
Rear port	-F	-T	-M	-C	-MD	-D2	-D3	-TB	-IS	-FE	-FA	-B	-K	-UB	-FD
RS485 (2 ports)	√														
Ethernet(2 ports)	■														
USB(1 port)	√														
Protocols	-F	-T	-M	-C	-MD	-D2	-D3	-TB	-IS	-FE	-FA	-B	-K	-UB	-FD
Modbus Serial	√														
Modbus over Ethernet	■														
IEC 60870-5-103	√														
TCP IEC 60870-5-103	■														
IEC 60870-5-101	√														
Measurement	-F	-T	-M	-C	-MD	-D2	-D3	-TB	-IS	-FE	-FA	-B	-K	-UB	-FD
4-20mA analog output	■														
Electric parameter	U、I、P、Q、PF、Fr、Ep、Eq、Es												U、Fr		
Logs and Records	-F	-T	-M	-C	-MD	-D2	-D3	-TB	-IS	-FE	-FA	-B	-K	-UB	-FD
Fault recorder	√														
Number of circuit breaker trip and close	√														
Sequence of event record	√														
Monitoring function	-F	-T	-M	-C	-MD	-D2	-D3	-TB	-IS	-FE	-FA	-B	-K	-UB	-FD
Trip-and-Close Circuit Supervision	√														
Remote control	√														
Others	-F	-T	-M	-C	-MD	-D2	-D3	-TB	-IS	-FE	-FA	-B	-K	-UB	-FD
GPS	√														
Protection Function	-F	-T	-M	-C	-MD	-D2	-D3	-TB	-IS	-FE	-FA	-B	-K	-UB	-FD
3 stages directional overcurrent (with voltage dependant)[ANSI 67]	√							√	√			√			
3 stages overcurrent (with composite voltage blocking)[ANSI 50/51]	√	√						√	√			√			
Differential protection with ratio restraining[ANSI 87]					√	√	√								
Instantaneous Differential protection[ANSI 87]					√	√	√								
Motor overcurrent(motor start,motor run,2 stages)			√		√										
Overcurrent (2 stages) [ANSI 50/51]				√											
Overcurrent IDMT [ANSI 51N]	√	√	√	√	√			√	√			√			
Bus charge												√			

Protection Function	-F	-T	-M	-C	-MD	-D2	-D3	-TB	-IS	-FE	-FA	-B	-K	-UB	-FD
Bus tie protection and standby power automatic switch												✓			
2 stages Directional earth fault [ANSI 67N]	✓							✓	✓			✓			
2 stages earth fault [ANSI 50N/51N]		✓	✓	✓	✓			✓							
Earth fault IDMT[ANSI 50N/51N]	✓	✓						✓	✓						
Clearance earth fault protection(2 stages)								✓							
Negative sequence overcurrent (2 stages)[ANSI 46]			✓		✓										
Negative sequence overcurrent IDMT[ANSI 46]			✓		✓										
Overload [ANSI 49F]	✓	✓	✓		✓			✓							
Starting air-cooled water chiller								✓							
On-load tap charge lock-out								✓							
Undervoltage (trip)[ANSI 27]			✓		✓				✓	✓	✓				
Undervoltage (alarm)[ANSI 27]			✓		✓				✓	✓	✓			✓	
Capacitor undervoltage(trip)				✓											
Loss of voltage (trip)	✓								✓						
Loss of voltage (alarm)	✓								✓						
Overvoltage protection[ANSI 59]	✓		✓	✓	✓				✓	✓				✓	
Residual voltage protection(trip)[ANSI 59N]	✓			✓	✓			✓	✓		✓				
Residual voltage protection(alarm)[ANSI 59N]			✓								✓			✓	
PT supervision[ANSI 60]	✓	✓	✓	✓	✓			✓	✓	✓	✓	✓		✓	
Unbalance voltage[ANSI 60]			✓	✓	✓										
Unbalance current[ANSI 60]				✓	✓										
Motor starting time-out[ANSI 48]			✓		✓										
CT supervision[ANSI 60]	✓	✓			✓	✓	✓		✓						
Three phase Auto-reclose[ANSI 79]	✓														
Thermal overload protection[ANSI 49M]			✓		✓										
Locked rotor[ANSI 51LR]			✓		✓										
FC block[ANSI 86]	✓	✓	✓		✓			✓	✓						
Post-accelerated overcurrent	✓											✓			
Under frequency[ANSI 81U]	✓								✓	✓	✓				
Over frequency[ANSI 81O]	✓								✓	✓	✓				
Incorrect phase sequence			✓		✓										
Voltage Phase loss protection			✓		✓										
Directional power protection[ANSI 32]	✓								✓						
Power recovery protection									✓						
Under power protection									✓						
Non-electricity	✓	✓	✓	✓	✓			✓	✓						✓
PT supervision and parallel connection														✓	
Synchro-check[ANSI 25]	✓								✓			✓			
Rate of change of frequency[ANSI 81R]									✓	✓					
Trip-and-Close Circuit Supervision(alarm)	✓	✓	✓	✓	✓			✓	✓	✓	✓	✓			

Protection Function	-F	-T	-M	-C	-MD	-D2	-D3	-TB	-IS	-FE	-FA	-B	-K	-UB	-FD
Auto-close with voltage recovery									√						
PT harmonic elimination														√	
Overhaul-lockout[ANSI 86]	√														

Note: √ means with this function, ■ means optional function, blank means without this function.

1.3 Relay Selection Table

A	M								
								Ethernet Interface:without	0
								with 1	1
								with 2	2
								Anti-pumping: without	0
								with	1
								4-20mA output: without	0
								with 2	2
								Power : 110V AC/DC	1
								220V AC/DC	2
								Zero sequence current input : 1A	1
								Zero sequence current input : 5A	5
								Current input: 1A	1
								Current input: 5A	5
							Version:	Line Protection Relay	F
								Transformer Protection Relay	T
								Motor Protection Relay	M
								Capacitor Protection Relay	C
								Standby power Automatic Transfer Relay	B
								Voltage Transformer Supervision and Parallel Connection Relay	UB
								Transformer Differential Protection Relay	D2
								Transformer Differential Protection Relay	D3
								Transformer protection Relay	TB
								Motor Differential Protection Relay	MD
								Public measurement and control relay	K
								Anti-islanding protection relay	IS
								Frequency and voltage Separation relay	FE
								Fault disconnection relay	FA
								Non-electricity relay	FD
							Serial number:		5SE
							Product series:		
							Manufacturer:	Acrel	

2 Technical Characteristics

2.1 Rated Characteristics

Version	AM5SE-F,AM5SE-T,AM5SE-M,AM5SE-C, AM5SE-B,AM5SE-D2,AM5SE-D3, AM5SE-TB,AM5SE-MD	AM5SE-UB, AM5SE-IS, AM5SE-FE, AM5SE-FA,AM5SE-K
Characteristics		
Power Supply		
Rated voltage	AC/DC 110V or AC/DC 220V	
Range	Rated voltage × (1±20%)	
Burden	≤15 VA	
PT Inputs		
Rated value	AC 100V or $100/\sqrt{3}$ V	AC 380V or 220V
PT rated secondary range	0.1V~120V	0.1V ~ 456V
Accuracy	0.5S	
Burden	≤0.5VA (each phase)	
Voltage withstand	Continuous: 1.2 Un 10s: 2 Un	
Phase CT Inputs (Protection Current)		
CT rated secondary range	AC 5A or 1A	
Dynamic	20 × CT rated current	
Accuracy	0.5S	
Burden	≤0.5VA (each phase)	
Thermal withstand	Continuous: 2 In 1s: 40 In	
Phase CT Inputs (Measurement Current)		
CT rated secondary range	AC 5A or 1A	
Dynamic	1.5 × CT rated current	
Accuracy	0.5S	
Burden	≤0.5VA (each phase)	
Thermal withstand	Continuous: 1.5 In 1s: 4 In	
Frequency		
Rated frequency	50Hz or 60Hz	
Frequency range	40 ~ 70Hz	
Accuracy	±0.1Hz	
Digital Inputs		

Operating nominal voltage	AC/DC 110V or AC/DC 220V
Voltage threshold	70% of nominal voltage
Reset threshold	55% of nominal voltage
Burden	≤ 1W (each phase) (DC220V)
Digital Outputs	
Make and carry	≥ 10000 operations
Making capacity	≥ 1000W, L / R = 40ms
Continuous current	≥ 5A
Short duration carry current	≥ 30A for 200ms
Breaking capacity	≥ 30W, L/R = 40ms

2.2 Protection characteristics

Characteristics	Accuracy	Resolution	Disengaging ratio
Voltage	±3%	0.001V	0.95 and 1.05
Current	±3%	0.001A	0.95 and 1.05
Frequency	±0.02Hz	0.001Hz	
Operation delay t>(DT)	40ms or ±2% setting value	0.001s	-
Operation delay t>(IDMT)	40ms or ±5% setting value	0.001s	-

2.3 Environmental characteristics

During operation: 10°C ~ +55°C, temperature; 5%~95%, humidity

Storage: -25°C ~ +70°C

Altitude: ≤ 2000m

Enclosure: IP20 (local panel)

2.4 Product safety

Insulation: Insulation resistance >100M Ω at 500Vdc

High voltages withstand: 2kV rms AC, 1 min:between all case terminals connected together, and the case earth/ground;

2 kV rms AC, 1 min:between all terminals of independent circuits

Impulse voltage: ±5kV (1.2/50 μ s, 0.5J)

2.5 Electromagnetic Compatibility Characteristics

Characteristics	Standard	Level/Class
Radiated emission	IEC-60255-26:2023—5.1	A
Conducted emission	IEC-60255-26:2023—5.2	A
Radiated radio frequency fields	IEC-60255-26:2023	A
Electrostatic discharge	IEC-60255-26:2023—6.1	B
Conducted radio frequency disturbance	IEC-60255-26:2023—6.2-6.5	A
Fast transient bursts	IEC-60255-26:2023—6.2-6.5	B
Slow damped oscillatory waves	IEC-60255-26:2023—6.2-6.4	B
Surges	IEC-60255-26:2023—6.2-6.4	B
Voltage dips and short interruptions test (AC or DC)	IEC-60255-26:2023—6.2	A/C ¹
Magnetic field at power frequency	IEC-60255-26:2023—6.1	B

¹ AC and DC voltage dips meet the criteria A/C of the IEC60255-26:2023—6.2. AC and DC voltage interruptions meet the criteria C of the IEC60255-26:2023—6.2. Ripple on DC input power port immunity meet the criteria A of the IEC60255-26:2023—6.2. DC auxiliary power supply ports gradually shutdown/start-up meet the criteria C of the IEC60255-26:2023—6.2.

3 Use

3.1 Front panel











The AM5SE relay is equipped with a user friendly local panel which is shown in Figure 3.1



Figure 3.1 AM5SE surface

3.2 Push buttons

Table 3.1 Push buttons

Symbol	Function	Symbol	Function
	Home key to return to the main screen.		Up navigation push-button for moving up in the menu or increasing a numerical value.
	Reset key to release latches and reset LED status.		Down navigation push-button for moving down in the menu or decreasing a numerical value.
	Esc key to return to the previous view.		Left navigation push-button for moving back across a menu or selecting a digit in a numerical value.
	Enter push-button for activating or confirming a function.		Right navigation push-button for moving forwards across a menu or selecting a digit in a numerical value.
	SOE key for viewing sequence of event.		Programmable function push-button for AM5SE.

3.3 Menu Description

The relay is powered on to enter the main screen(Mimic screen), and can take turns display Measurement, Remote Signal, DO Mapping by pushing the  key.

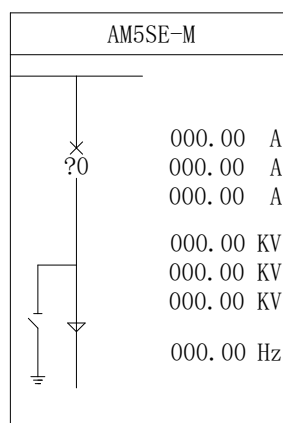

Figure 3.2 Mimic screen

Measurement		
Ia	0000.000	A
Ib	0000.000	A
Ic	0000.000	A
I1	0000.000	A
I2	0000.000	A
I01	0000.000	A
I02	0000.000	A
IA	0000.000	A
IB	0000.000	A
IC	0000.000	A
UAB	0000.000	V
UBC	0000.000	V

Measurement		
UCA	0000.000	V
U4	0000.000	V
Fr	0000.000	Hz
P	0000.000	KW
PF	0000.000	
U1	0000.000	V
U2	0000.000	V
Uav	0000.000	V
U20	0000.000	V
Q	0000.000	KVar
Ep	0000.000	kw*h
Eq	0000.000	kVar*h

Measurement		
AO_1	0000.000	mA
AO_2	0000.000	mA
Ia_H2	0000.000	A
Ib_H2	0000.000	A
Ic_H2	0000.000	A
Uub	0000.000	%
Iub	0000.000	%
S	0000.000	KW
Es	0000.000	kw*h
QFcnt	0000.000	
Ep+	0000.000	kw*h
Ep-	0000.000	kw*h

Figure 3.3 Measurement

RemoteSignal	
CB ON	OFF
CB OFF	OFF
Work Posi.	OFF
Test Posi.	OFF
GroundSwitch	OFF
Remote	OFF
Discharge	OFF
Spare6	OFF
Non-elec.1	OFF
Non-elec.2	OFF
Heat Recovery	OFF
Low Speed	OFF

RemoteSignal	
ManualTrip	OFF
ManualClose	OFF
Spare5	OFF
ResetSignal	OFF
LoadSW. On	OFF
LoadSW. Off	OFF
Spare2	OFF
Spare1	OFF
Power. L. Det	OFF
DO Test	OFF
Posi. Aft. CB. On	OFF
ManualTrip. M	OFF

RemoteSignal	
CB On. M	OFF
CB Off. M	OFF
ManualClose. M	OFF

Figure 3.4 Remote Signal

All of the digital inputs can be showed on the “Remote Signal” screen. When the digital input is tied to the supply voltage, the state of this DI will be “ON”, otherwise the state of the DI is “OFF”.

DO Mapping
RemoteTrip
00000 00100 00100 0
RemoteClose
00000 00000 00010 0
3I>>>.S
00000 00100 10000 0
3I>>>.R
00000 00100 10000 0
3I>
00000 00100 10000 0
I0>
00000 00100 10000 0

DO Mapping
U. Amp. T
00000 00100 10000 0
U. Phase. T
00000 00100 10000 0
Non-elec1. T
00000 00100 10000 0
OverHeat. T
00000 00100 10000 0
Sta. OutT. T
00000 00100 10000 0
CloseBlock
00000 00000 00000 1

DO Mapping
Trip Load
00010 00000 00000 0
FC Block
00000 00010 00000 0
Alarm
00000 00100 00000 0
Accident. S
00000 00000 00001 0
DO Test
11111 11111 11111 0
Ph. Se. S
00000 00100 00000 0



Figure 3.5 DO Mapping

In the DO mapping interface, the mapping relationship between protection function and digital output is shown in the following table with 1-16 binary digits.

1	2	3	4	5	6	7	8	9	10	11	12	13	14	15	16
0	0	0	0	0	0	0	0	0	0	0	0	0	0	0	0

1 - 10 represent passive output DO1 - DO10, respectively; 11 - 15 represent protection trip, protection close, remote trip, remote close, and accident signal in trip-and-close circuit, respectively; and 16 represents internal closing block relay. If one of the number from 1 to 16 is 1, indicating that the protection function is configured to this output; if it is 0, indicating that the output is not configured.

3.3.1 Navigation

The menu of relay is multi-level menu; Press the  key to enter the main menu. There are 9 sub menus in the main menu, as shown as figure 3.6, which is composed of names and icons of sub menus. Press the  key to enter either sub menu in the main menu, and press the  key to return to the superior menu. Figure 3.7 shows the navigation diagram of the relay, which can be used to find relevant parameters quickly.

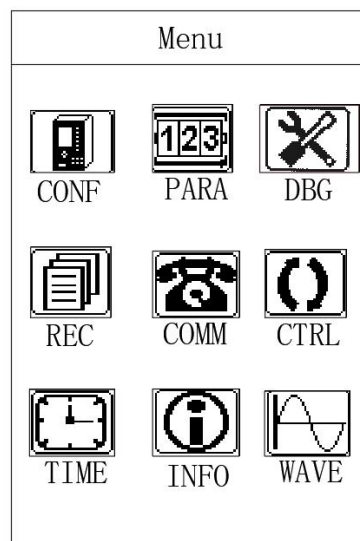

Figure 3.6 Main menu

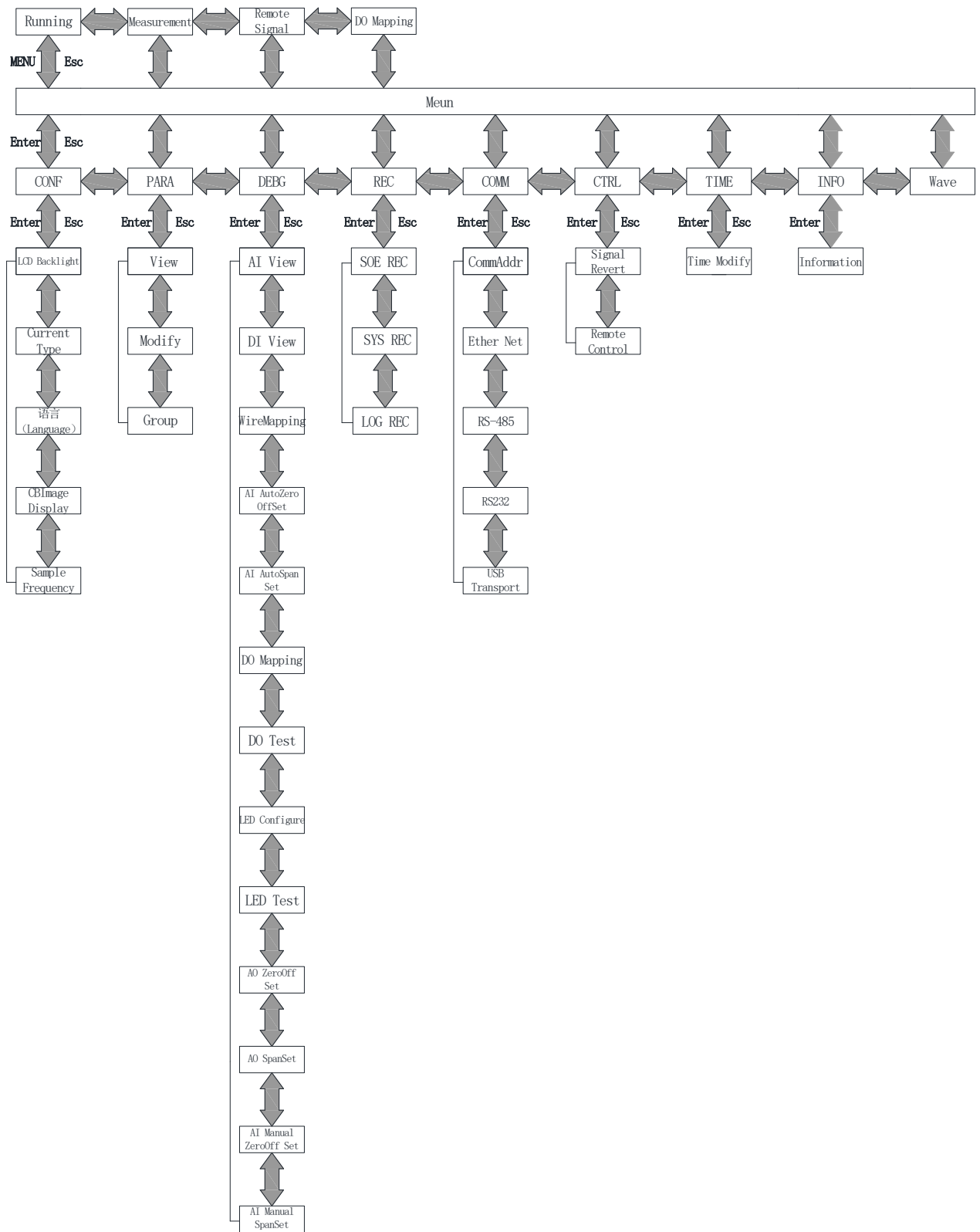

Figure 3.7 Navigation diagram

3.3.2 Configuration





The "Conf" menu can set the LCD backlight time, as shown in Figure 3.8. After modification, press the  key to confirm the modification and press the  to return to main menu .The data saving interface will pop up, as shown in Figure 3.9 ;Press the  key to save the modification and return to the main menu, or press the  key to return to the main menu directly without saving the modification.



Figure 3.8 LCD backlight time setting

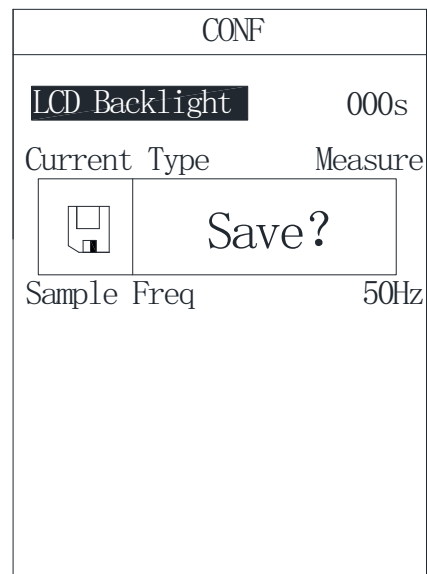





Figure 3.9 Data saving

3.3.3 Parameter

The "Para" menu includes 3 sub-menus: Value View, Value Modify and Switch Group, as shown in Figure 3.10.

A) Value View

The "Value View" menu includes two sub-menus: "Selected" and "Running". There are 4 groups of valid value in the "Selected", which are 00, 01, 02, and 03 areas. After selecting the corresponding area, as shown in Figure 3.11, press the  key to enter the "Value View" menu.

All values can be viewed page by page by the  and  key , as shown as figure 3.12. The "Running" shows the current running area of the relay.

PARA
Value View
Value Modify
Switch Group

Fig. 3.10 Parameter

Value Group
Selected: 00
Running: 00









Fig. 3.11 Selection area



View[00]	(001/113)
CT	0300.00
PT	0100.00
PT Mode	2PT
CT Mode	2CT
U Unit	KV
Ie1	300.000A

Fig. 3.12 Value View

B) Modify

The "Modify" menu includes two sub menus: "Selected" and "Running". The initial password of this menu is "0008".

Set the group code in the "Selected", and enter the "Modify" by the  key. All the values are showed page by page, and select the values which need to be modified by the , ,  and  keys. The values can be selected by the  key, and be modified by the  and  key, as shown as figure 3.14. After the modification, press the  key to confirm the modification, and then set the next value as the same way.

After all modifications, press the  key to quit the "Modify". If value has been changed, the data saving interface will pop up, as shown as figure 3.9. Press the  key to save the modification and return to the "Menu". If press the  key, relay will return to the "Menu" directly without saving the modification.

The "Running" interface only shows the current running area of the relay, and no modification is made here.

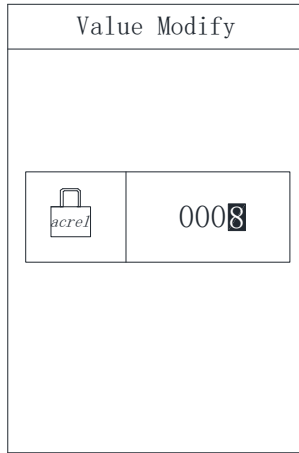

Fig. 3.13 Enter Password

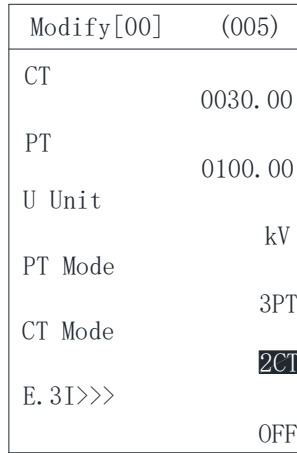

Fig. 3.14 Modify

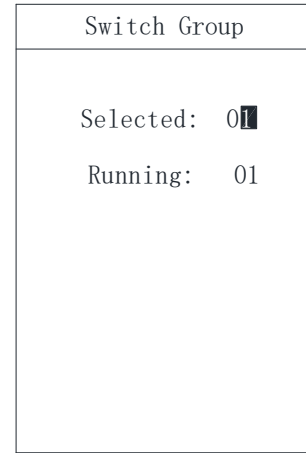

Fig. 3.15 Group

C) Group

The "Group" menu includes two sub menus: "Selected" and "Running". The initial password of this menu is "0008". There are four valid groups from 00 to 03 in the "Group". After setting, the modification can be confirmed by the "Enter" key, and then return to the main menu by the "Esc" key. The running value area will display the current running value area of the relay, as shown in Figure 3.15.

3.4 Debug

The "Debug" menu is used to test before delivery. The function includes zero adjustment, amplitude adjustment, relay output test, LED test, LED color configuration, and relay output configuration.

When use the "Debug" menu, please contact the manufacturer first!

3.5 Record

The "REC" includes 3 types of record: SOE Record, System Record and LOG Record.

A) SOE Record

The "SOE" menu shows the event sequence, total number of events, event code, event time, event name, action type (trip or alarm), and other information. It can also record the action values and time of the protection event, as shown in Figure 3.16. The relay can save more than 200 event records.

B) System Record

The "SYS" menu shows the error sequence, error counts, error time, error name, error code and so on, as shown in Figure 3.17. The relay can save more than 200 error records.

SOE REC	
NO.	[010/012]
ALL	(000)
	2022-09-14
	16:18:47.304
	3I>>>
	[Set]
SOE Para:	
Ia	4.987A
Ib	4.987A
Ic	4.985A
UAB	0.035V
UBC	0.059V
UCA	0.025V
U2	0.019V
Ia_H2	0.008A

Figure 3.16 Event record screen

SYS REC	
[002/005]	
2022-02-22	
23:27:51	
Software Init	
code: 0x00000003	

Figure 3.17 System record screen

C) Log Record

As shown in Figure 3.18, the "Log" menu records all operations and setting changes of the relay.

LOG Rec	[001/033]
20011223-123456.0123	
Device power on/off	
ON	

Figure 3.18 Log record screen

3.6 Communication

As shown in Figure 3.19, the "Comm" menu can set the communication address of relay and baud rate. Figure 3.20 shows the relay's communication address set. The communication mode has four interface settings: Ethernet interface, RS485 interface, RS232 interface, and USB interface.

As shown as Figure 3.21, 3.22, and Table 3.3, the communication parameters of 2 Ethernet ports (network A and network B) can be set.

Table 3.3 Ethernet port communication parameters setting

Local TCP mode	Set on demand, can be set to the same within the same network
Local TCP port	Set on demand, can be set to the same within the same network
Local UDP port	Set on demand, can be set to the same within the same network
Local Mac address	Non-repeatable within the same network
Local IP address	Non-repeatable within the same network
Remote IP address	The IP of the backend machine, which can be set to the same within the same network
Remote TCP port	The IP of the backend machine, which can be set to the same within the same network
Gateway	Set on demand, can be set to the same within the same network
Subnet Mask	Set on demand, can be set to the same within the same network

As shown in Figure 3.23, the communication parameters of two RS485 ports (com1 and com2) can be set.

As shown in Figure 3.24, communication parameters of RS232 port (com3) can be set to realize relay program upgrade.

As shown in Figure 3.19, enter the "USB Transport" menu to upgrade the program of the relay.

Please contact the manufacturer when using this menu function.

Communication parameters can be set by selecting parameters from Table 3.4. After setting, press the "Esc" key to exit, then press the "Enter" key to save and then press the "Esc" key to return to the main menu.

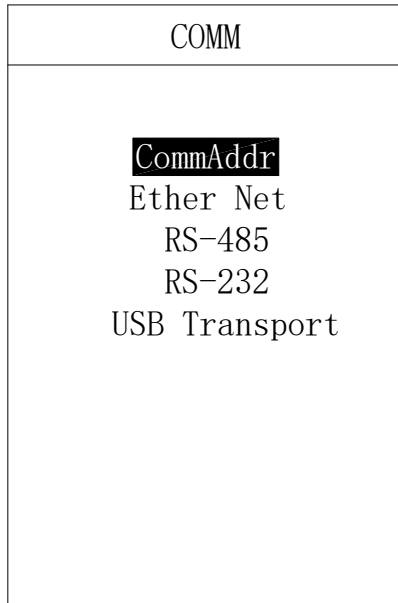

Fig. 3.19 Communication menu

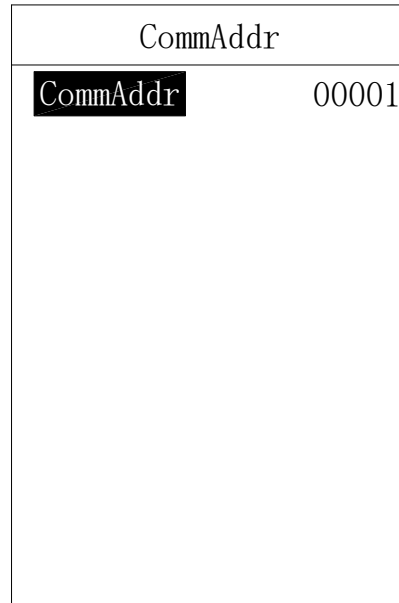

Fig. 3.20 Relay address setting interface

Ether Net	Enet_A
Protocol:	Modbus
LocalTcpMode:	Server
LocalTcpPort:	7710
LocalUdpPort:	1032
LocalMacAddr:	41-63-72-65-6C-41
LocalIpAddress:	192.168.001.002

Fig. 3.21 Enet_A communication parameters

Ether Net	Enet_A
RemoteTcpPort:	1048
RemoteIpAddress:	172.020.000.000
Gateway:	192.168.001.001
SubnetMask:	255.255.255.000

Ether Net	Enet_B
Protocol:	Modbus
LocalTcpMode:	Server
LocalTcpPort:	7720
LocalUdpPort:	1032
LocalMacAddr:	41-63-72-65-6C-42
LocalIpAddress:	192.168.001.003

Fig. 3.22 Enet_B communication parameters

RS-485	
COM1 Protocol:	Modbus
COM1 BaudRate:	19200
COM1 DataBit:	8
COM1 StopBit:	1
COM1 Parity:	NONE
COM2 Protocol:	Modbus
COM2 BaudRate:	19200
COM2 DataBit:	8
COM2 StopBit:	1
COM2 Parity:	NONE

Fig. 3.23 RS-485 communication parameters

RS-232	
COM3 Protocol:	Modbus
COM3 Baudrate:	115200
COM3 DataBit:	8
COM3 StopBit:	1
COM3 Parity:	NONE

Fig. 3.24 RS-232 communication parameters

Table 3.3 Communication parameter setting

Setting	Parameter
Relay address	0 to 255
Baud rate	110, 300, 600, 1200, 2400, 4800, 9600, 14400, 19200, 38400, 56000, 57600, 115200, 128000, 256000
Data bits	8, 9
Stop bits	1, 1.5, 2
Parity mode	No parity, Even parity, Odd parity
Protocol selection	Modbus-RTU、 IEC103、 IEC101、 LoopB
Local TCP mode	Server, Client

3.7 Control

The "Control" menu is used to test before delivery. The function in this menu includes remote trip、 remote close and signal reset.

When use the "Ctrl" menu, please contact the manufacturer first!

3.8 Time

The "Time" menu is used to modify the clock. As shown in Figure 3.26, press the "Enter" key after the time setting is completed, then press the "Esc" key to return to the main menu.

Time Modify	
Current Time	
2023-06-20	
11:24:14	
Y-M-D:	2023-06-20
H:M:S	11:22:18

Fig. 3.26 Time Setting

3.9 Information

The "Information" menu can display the basic information includes relay's name、 version、 check code、 hardware、 software、 logic、 logic version and so on, as shown in Figure 3.27.

INFO
AM5SE-M
HalVer: 1.21
CRC code: 0x1f37
Hardware:
2021-12-20_01:07:26
Software:
2021-12-20_01:07:28
LogicVer:
T0025 1.16
2021-12-20_01:07:37

Fig 3.27 Information

4 Dimensions and Installation

4.1 Dimensions and Cut-out dimensions

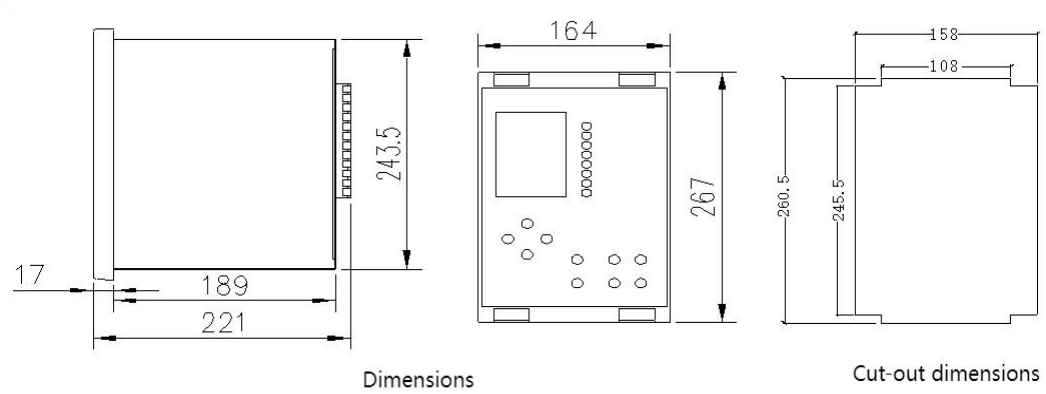
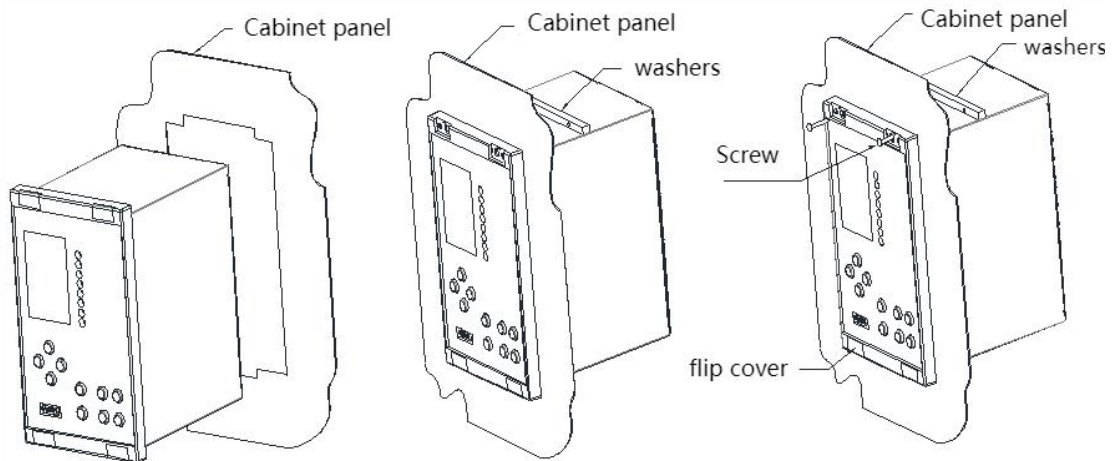

Figure 4.1 Dimensions and cut-out dimensions

Note: Length unit is millimeter (mm).

4.2 Installation procedure



1. Prepare the cut-out in the panel for the flush installation according to the above dimensions.
2. Fasten the AM5SE protection relay in its position with four M3×12mm screws with washers.
3. Cover four small flip covers on the four screws again.

5 Wiring

5.1 AM5SE rear panel

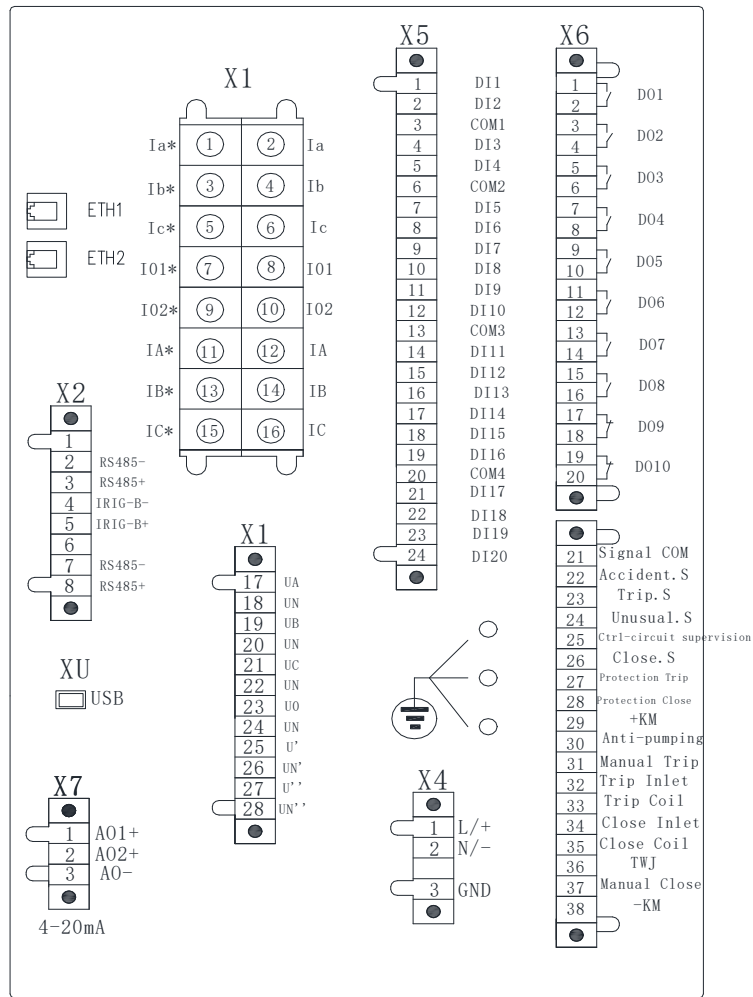

Figure 5.1 AM5SE

X1	1-16	Current
X1	17-28	Voltage
X2	1-8	RS-485 and IRIG-B
X4	1-2	Power supply
X4	3	Power ground
X5	1-24	Digital inputs
X6	1-20	Digital outputs
X6	21-38	Anti-pumping and trip and close supervision
X7	1-3	Analog output
ETH	1-2	Ethernet
XU	USB	

5.2 Typical application

The following describe typical application diagrams. 3CTs and residual current, 3PTs and residual voltage have been showed in the diagrams.

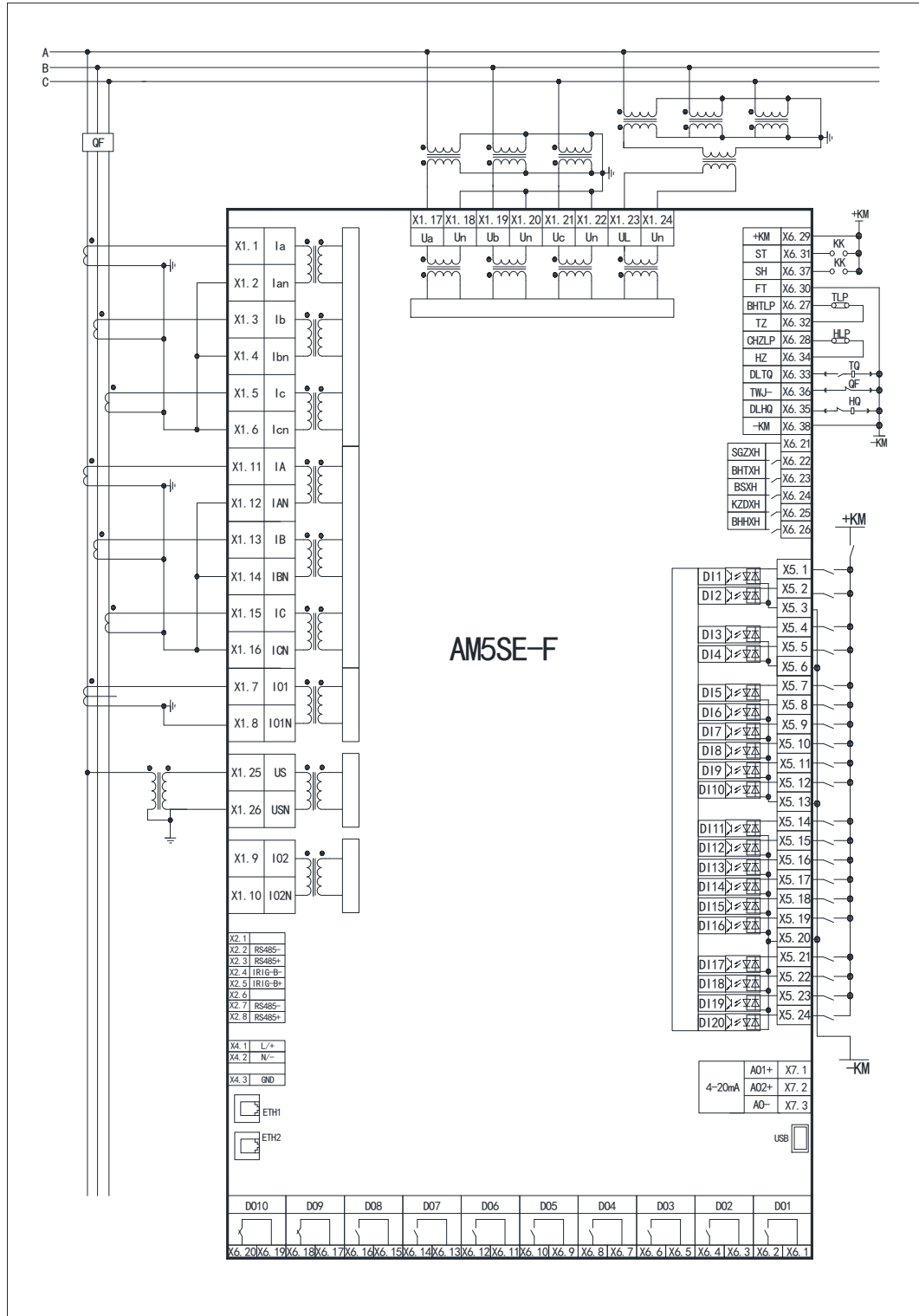

Figure 5.2 Typical application diagrams

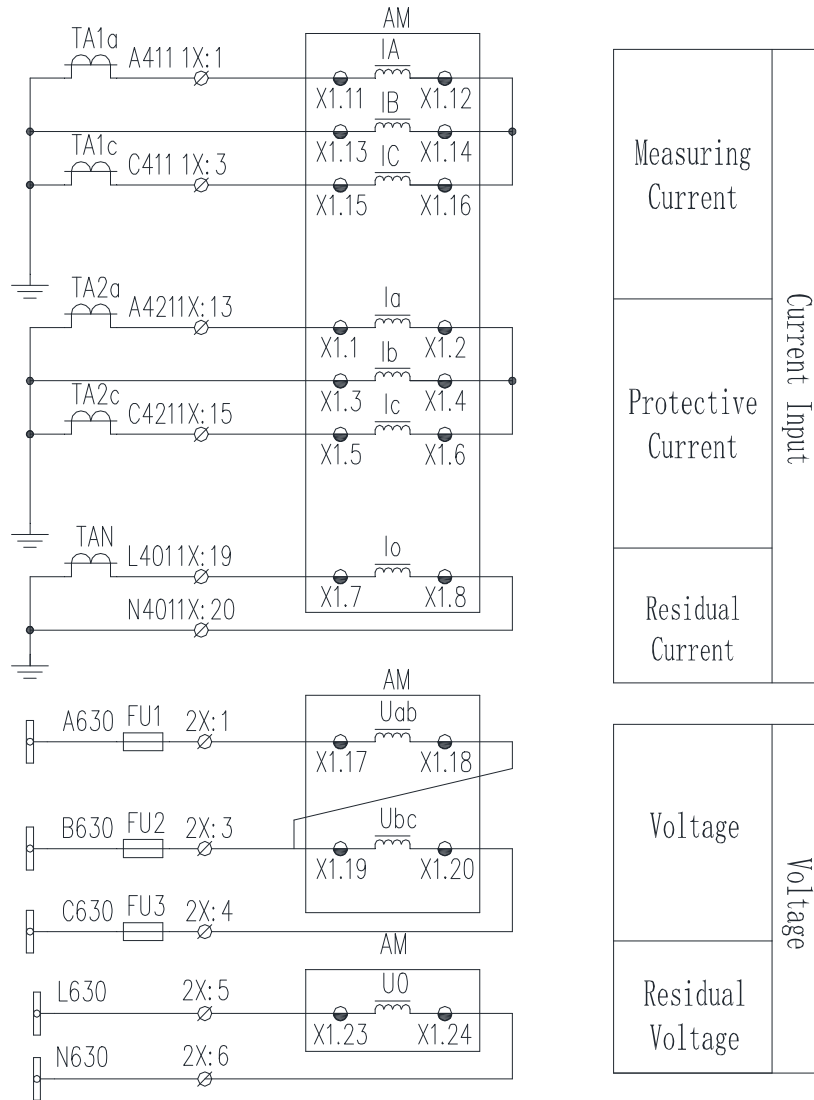

Figure 5.3 2PT & 2CT Wiring

6 Product maintenance

The following table shows the common problems and treatment methods of the AM5SE during use.

Table 6.1 Common problems and treatment methods

Questions	Possible causes	Treatment suggestion
The trip relay doesn't close.	<ol style="list-style-type: none"> 1、 Corresponding function is not enabled. 2、 Conditions for closure. 3、 Incorrect DO mapping. 	<ol style="list-style-type: none"> 1、 Set the corresponding protection enable on; 2、 Check the blocking condition. 3、 Configure the corresponding digital output in the "DBG" menu. 4、 Please contact after-sales staff.
Communication failure.	<ol style="list-style-type: none"> 1、 The polarity of communication cable is reversal. 2、 Communication parameter and protocol are inconformity. 3、 Communication cable break. 4、 Wrong communication address. 	<ol style="list-style-type: none"> 1、 Check the wiring. 2、 Reset communication parameters and protocols. 3、 Repair or replace the communication cable. 4、 Reset the communication address in the "COMM" menu.
Ethernet communication failure.	<ol style="list-style-type: none"> 1、 Communication parameter and protocol are inconformity. 2、 Communication cable break. 	<ol style="list-style-type: none"> 1、 Reset communication parameters and protocols. 2、 Repair or replace the communication cable.
No current on the main interface.	Wrong configuration option of "Current Type".	Reset the "Current Type" in the "CONF" menu.
The LED is always on . The color of LED doesn't match the setting.	<ol style="list-style-type: none"> 1、 The relay is initializing. 2、 Wrong configuration of the LED'S color. 	<ol style="list-style-type: none"> 1、 Please press "RST" button once. 2、 Please contact after-sales staff
The voltage value is incorrect.	The "PT mode" is different from the wiring.	Reset the "PT mode" according to the wiring.
No digital signal acquisition.	No signal input to corresponding digital input.	Measure the voltage between the corresponding digital input and the common terminal of the relay. Check whether the voltage is normal.
Manual closing of the circuit breaker is unsuccessful.	Manual trip and manual close are short-circuit.	Remove the wiring of X6.33, X6.35 and X6.29 from the relay. Connect the X6.37 to positive power supply directly and check on-off state between X6.29 and X6.32 .
After manual closing, closing coil of circuit	There is no NC before the closing coil of circuit breaker.	Insert a NC between the X6.35 and the closing coil of circuit breaker.

breaker remains energized.		
Manual tripping of the circuit breaker is unsuccessful.	1. TBJ relay circuit is abnormal. 2. STJ relay circuit is abnormal. 3. Wiring to the X6.38 is unreliable.	1. Test whether the protective trip and remote trip are normal; 2. Check wiring of X6.38 and confirm that the wiring is correct and reliable; 3. Remove the wiring of X6.29 from the relay. Manual trip and check the on-off state between X6.29 and X6.32.

The procedure for testing the anti-pump function is as follows:

- 1、 Cancel the X6.30 anti-pump contact of relay, short the manual close contact, at this time the circuit breaker close, manual trip circuit breaker. After several manual operations, if the circuit breaker still keeps in the close state, it means that the circuit breaker does not equip with anti-pump function; After several manual operations, if the circuit breaker keeps in the trip state , it means that the circuit breaker equip with anti-pump function;
- 2、 After confirming that the circuit breaker does not equipped with anti-pump function, connect the X6.30 anti-pump contact to the negative power supply and use the AM5SE relay's anti-pump. At this time, short the manual closing contact, the circuit breaker is closed, and manual trip once. After several manual operations, the circuit breaker keeps in the trip state, which means that the anti-pump function is triggered; release the wire of manual closing. Waiting for 10s and then manual close the breaker. At this time, the circuit breaker can be closed normally, indicating that the anti-pump lock state is released.

Appendix A Setting value

AM5SE-F 定值表				
AM5SE-F Setting				
保护名称 Protection Function	定值名称 Value Name	默认值 Default	范围 Range	备注 Notice
	CT 变比 CT	10	0.1~9999	
	PT 变比 PT	100	0.1~9999	
	一次电压显示 U Unit [Primary voltage display]	0	0~1	kV;V
	电压接线方式 PT Mode [Voltage measurement mode]	0	0~1	3PT; 2PT
	电流接线方式 CT Mode [Current measurement mode]	0	0~1	3CT; 2CT
过流一段 3I>>> [50] [Instantaneous overcurrent]	过流一段投退 E.3I>>> [Enable.3I>>>]	0	0~1	退出; 投入 OFF; ON
	一段带方向 E.3I>>>.D[67] [Enable.3I>>> .direction]	0	0~1	不带方向; 指向线路; 指向母线; 指向线路和 母线 OFF;Line; Bus; Line&Bus
	一段经低压 E.3I>>>.U [Enable.3I>>> .Voltage]	0	0~1	退出; 投入 OFF; ON [If enable 3I>>>.U, voltage conditions should be considered for overcurrent protection. When the smallest of the three line voltages is less than U.Under and greater

				than U.Less, the overcurrent protection DO is prepare work.]
	过流一段定值 3I>>> [3I>>> value]	10A	0.04~100	
	过流一段延时 3I>>>.T [3I>>> delay]	0s	0~60	
	一段指向线路定值 3I>>>L [Enable 3I>>>.Line value]	10A	0.04-100	
	一段指向线路延时 3I>>>L.T [3I>>> Line delay]	0s	0~60	
	一段指向母线定值 3I>>>B [Enable 3I>>>.Bus value]	10A	0.04-100	
	一段指向母线延时 3I>>>B.T [3I>>> Bus delay]	0s	0~60	
过流二段 3I>> [51] [Time-limited overcurrent]	过流二段投退 E.3I>> [Enable.3I>>.]	0	0~1	退出；投入 OFF； ON
	二段带方向 E.3I>>.D[67] [Enable.3I>> .direction]	0	0~1	不带方向；指向线路； OFF； Line；
	二段经低压 E.3I>>.U [Enable.3I>> .Voltage]	0	0~1	退出；投入 OFF； ON [If enable 3I>>.U, voltage conditions should be considered for overcurrent protection. When the smallest of the three line voltages is less

				than U.Under and greater than U.Less, the overcurrent protection DO is prepare work.]
	过流二段定值 3I>> [3I>> value]	7.5A	0.04~100	
	过流二段延时 3I>>.T [3I>> delay]	0.2s	0~60	
	二段指向线路定值 3I>>L [3I>>.Line value]	7.5A	0.04-100	
	二段指向线路延时 3I>>L.T [3I>> Line.delay]	0.2s	0~60	
	二段指向母线定值 3I>>B [3I>>.Bus value]	7.5A	0.04-100	
	二段指向母线延时 3I>>B.T [3I>> Bus.delay]	0.2s	0~60	
过流三段 3I> [51] [Definite time overcurrent]	过流三段投退 E.3I> [Enable.3I>]	0	0~1	退出；投入 OFF；ON
	三段带方向 E.3I>.D[67] [Enable.3I> .direction]	0	0~1	不带方向；指向线路 OFF；Line
	三段经低压 E.3I>.U [Enable.3I> .Voltage]	0	0~1	退出；投入 OFF；ON [If enable 3I>.U, voltage conditions should be considered for overcurrent protection. When the smallest of the

				three line voltages is less than U.Under and greater than U.Less, the overcurrent protection DO is prepare work.]
	过流三段定值 3I> [3I> value]	7A	0.04~100	
	过流三段延时 3I>.T [3I> delay]	0.5s	0~60	
	三段指向线路定值 3I>L [3I>.Line value]	7A	0.04-100	
	三段指向线路延时 3I>L.T [3I>Line delay]	0.5s	0~60	
	三段指向母线定值 3I>B [3I>.Bus value]	7A	0.04-100	
	三段指向母线延时 3I>B.T [3I> Bus delay]	0.5s	0~60	
反时限过流 I>Inv [51] [Inverse time overcurrent (IDMT)]	反时限过流投退 E. I>.Inv [Enable I> Inverse]	0	0~1	退出; 投入 OFF; ON
	反时限经低压 E.I>.Inv.U [Enable I>Inverse Voltage]	0	0~1	退出; 投入 OFF; ON [If enable I>.Inv.U, voltage conditions should be considered for overcurrent protection. When the smallest of the three line voltages is less than U.Under and greater

				than U.Less, the overcurrent protection DO is prepare work.]
	反时限启动电流 I>.Inv [Inverse current]	5A	0.04~100	
	反时限时间系数 I>.Inv.K [Inverse time coefficient]	0.1s	0.1~100	
	反时限曲线类型 I>.Inv.X [Inverse curve]	0	0~2	一般；非常；极端 NI；VI；EI
过负荷告警 I>Lo.A [49F] Overload Alarm	过负荷告警投退 E.I>Lo.A [Enable Overload Alarm]	0	0~1	退出；投入 OFF；ON
	过负荷告警定值 I>Lo.A [Overload Alarm value]	6.5A	0.04~100	
	过负荷告警延时 I>Lo.A.T [Overload Alarm delay]	5s	0~999	
过负荷跳闸 I>Lo.T [49F] Overload Trip	过负荷跳闸投退 E.I>Lo.T [Enable Overload Trip]	0	0~1	退出；投入 OFF；ON
	过负荷跳闸定值 I>Lo.T [Overload Trip value]	6A	0.04~100	
	过负荷跳闸延时 I>Lo.T.T [Overload Trip delay]	10s	0~60	
后加速过流 Post-Accelerated Overcurrent	后加速过流投退 E. I>P [Enable post-accelerated overcurrent]	0	0~1	退出；投入 OFF；ON
	后加速经低压	0	0~1	退出；投入

	I>P.U [Enable I>P voltage]			OFF; ON [If enable I>P.U, voltage conditions should be considered for overcurrent protection. When the smallest of the three line voltages is less than U.Under and greater than U.Less, the overcurrent protection DO is prepare work.]
	后加速过流定值 I>P [Post-accelerated overcurrent value]	6.5A	0.04~100	
	后加速过流延时 I>P.T [Post-accelerated overcurrent delay]	0s	0~60	
I01 过流一段 I01>>> [50N] [Instantaneous ground fault overcurrent]	I01 一段投退 E. I01>>>> [Enable I01>>>>]	0	0~1	退出; 投入 OFF; ON
	I01 一段带方向 I01>>>>D[67N] [Enable.I01>>>>.direction]	0	0~2	不带方向; 指向线路; 指向母线 OFF; Line; Bus
	I01 一段定值 I01>>>> [I01>>>> value]	10A	0.04~100	
	I01 一段延时 I01>>>>.T [I01>>>> delay]	5s	0~60	
	I01 一段 3U0 值 I01>>>>.3U0 [I01>>>>.self-produced U0]	2V	0~200	
I01 过流二段	I01 二段投退	0	0~2	退出; 告警; 跳闸

I01>> [51N] [Time limited ground fault overcurrent]	E. I01>> [Enable I01>>]			OFF; Alarm; Trip
	I01 二段带方向 E. I01>>>D[67N] [Enable.I01>>> .direction]	0	0~2	不带方向; 指向线路; 指向母线 OFF; Line; Bus
	I01 二段定值 I01>> [I01>> value]	9A	0.04~100	
	I01 二段延时 I01>>.T [I01>> delay]	10s	0~60	
	I01 二段 3U0 值 I01>>.3U0 [I01>>.self-produced U0]	2V	0~200	
I02 过流一段 I02>>> [50N] [Instantaneous ground fault overcurrent]	I02 一段投退 E. I02>>>> [Enable I02>>>>]	0	0~1	退出; 投入 OFF; ON
	I02 一段带方向 E. I02>>>>D[67N] [Enable.I02>>>> .direction]	0	0~2	不带方向; 指向线路; 指向母线 OFF; Line; Bus
	I02 一段定值 I02>>>> [I02>>>> value]	10A	0.04~100	
	I02 一段延时 I02>>>>.T [I02>>>> delay]	5s	0~60	
	I02 一段 3U0 值 I02>>>>.self-produced U0 [I02>>>>.self-produced U0]	2V	0~200	
I02 过流二段 I02>>> [50N] [Time limited ground fault overcurrent]	I02 二段投退 E. I02>>>> [Enable I02>>>>]	0	0~2	退出; 告警; 跳闸 OFF; Alarm; Trip
	I02 二段带方向 E. I02>>>>D [67N] [Enable.I02>>>> .direction]	0	0~2	不带方向; 指向线路; 指向母线 OFF; Line; Bus

	I02 二段定值 I02>> [I02>> value]	9A	0.04~100	
	I02 二段延时 I02>>.T [I02>> delay]	10s	0~60	
	I02 二段 3U0 值 I02>>.self-produced U0 [I02>>.self-produced U0]	2V	0~200	
PT 断线告警 PT supervision[60]	PT 断线告警投退 E.PtBr.A [Enable PT Break alarm]	0	0~1	退出; 投入 OFF; ON
	PT 断线告警延时 PtBr.T [PT Break delay]	10s	0~999	
	无压定值 U.None [No-voltage]	15V	0~200	[Less than U.None means that there is no voltage]
	无流定值 I.None [No-current]	0.2A	0.04~100	[Less than I.None means that there is no current]
	PT 断线负序电压 U2.Pt [Negative sequence voltage]	35V	0~200	
控故障告警 Trip and close circuit supervision	控故障告警投退 E.CB.A [Enable Trip and close circuit supervision alarm]	0	0~1	退出; 投入 OFF; ON
	控故障告警延时 CB.A.T [Trip and close circuit supervision alarm delay]	10s	0~999	
	低压阈值 U.Less [Under voltage threshold]	15V	0~200	

	低电压定值 U. Under [Under voltage value]	70V	0~200	
低频减载 [81U] Under-Frequency Protection	低频减载投退 E.UnderFr. [Enable Under Frequency]	0	0~1	退出; 投入 OFF; ON
	低压闭锁 E. UnderFr.U [Enable Under Frequency Voltage block]	0	0~1	退出; 投入 OFF; ON
	欠流闭锁 E.UnderFr.I [Enable Under Frequency current block]	0	0~1	退出; 投入 OFF; ON
	滑差闭锁 E.UnderFr.dHz. [Enable Under Frequency slip block]	0	0~1	退出; 投入 OFF; ON
	低频减载定值 UnderFr. [Under Frequency value]	49Hz	40~70	
	低频减载延时 UnderFr.T [Under Frequency delay]	3s	0~60	
	滑差闭锁值 dHz.B [Under Frequency slip block value]	0.1Hz/s	0.1~10	
	欠流闭锁值 I. B [Under Frequency current block value]	5A	0.2~100	
	低压闭锁值 U. B [Under Frequency voltage block value]	50V	0~200	
	重合闸 Auto-Recloser function [79]	重合闸投退 E. Reclose [Enable Auto-Reclose]	0	0~1
重合闸延时 Reclose.T		5s	0.1~ 9999.999	

	[Auto-Reclose delay]			
	重合闸方式 Reclose.X [Auto-reclose Mode]	0	0~1	不检；检无压 Not Check； Check
	重合闸充电延时 Rec.C.T [Auto-reclose charge delay]	5s	0.1~ 9999.999	
	重合闸充电返回 T RecC.RT [Auto-reclose charge return time]	1s	0~9999.999	
	保护重合返回延时 T.R.T [Trip auto-reclose return time]	30s	0~9999.999	
	不对应重合投退 E. nonP. [Enable non-position auto-reclose]	1	0~1	退出；投入 OFF； ON
FC 配合的过流闭锁 功能 FC Block	FC 闭锁投退 E. FCBlock [Enable FC Block]	0	0~1	退出；投入 OFF； ON
	FC 闭锁电流定值 FCBlock.I [FC Block current value]	10A	0.04~100	
	FC 闭锁延时 FCBlock.T [FC Block delay]	5s	0~60	
I01 反时限过流 I01.Inv [51N] [Inverse time ground fault]	I01 反时限投退 E. I01.Inv [Enable I01.Inverse]	0	0~1	退出；投入 OFF； ON
	I01 反时限启动值 I01.Inv [I01.Inverse value]	5A	0.04~100	
	I01 反时限系数 I01.Inv.K [I01.Inverse time coefficient]	0.5s	0~100	
	I01 反时限曲线 I01.Inv.X	0	0~2	一般；非常；极端 NI； VI； EI

	[I01.Inverse curves type]			
I02 反时限过流 I02.Inv [51N] [Inverse time ground fault]	I02 反时限投退 E. I02.Inv [Enable I02.Inverse]	0	0~1	退出；投入 OFF；ON
	I02 反时限启动值 I02.Inv [I02.Inverse value]	5A	0.04~100	
	I02 反时限系数 I02.Inv.K [I02.Inverse time coefficient]	0.5s	0~100	
	I02 反时限曲线 I02.Inv.X [I02.Inverse curves type]	0	0~2	一般；非常；极端 NI；VI；EI
低电压跳闸 LVP.T [27] [Undervoltage Trip]	低电压跳闸投退 E. LVPT [Enable Undervoltage Trip]	0	0~1	退出；投入 OFF；ON
	低电压跳闸定值 LVP.T [Undervoltage Trip value]	50V	1~200	
	低电压跳闸延时 LVP.T.T [Undervoltage Trip delay]	5s	0~60	
	无流闭锁投退 E.LVPT.I.B [Enable Undervoltage Trip current block]	0	0~1	退出；投入 OFF；ON [If enable LVP.I.B, when the current is less than I.None, under voltage protection will be blocked.]
	PT 断线闭锁投退 E.T.PT.B [Enable PT break trip block]	1	0~1	退出；投入 OFF；ON [When PT break occurs, the relay will send an alarm signal and lock out the under voltage protection.]
	合位允许投退 E.CB.OnT.B [Enable circuit breaker on Trip block]	0	0~1	退出；投入 OFF；ON

	低电压阈值投退 E.T.LVTHr. [Enable Undervoltage Trip threshold]	1	0~1	退出; 投入 OFF; ON [If enable LVTHr. , when the voltage is greater than U.None and less than U.LVP , under voltage protection will act. If exit LVTHr. , under voltage protection is Loss voltage protection.]
低电压告警 LVP.A [27] [Undervoltage Alarm]	低电压告警投退 E.LVP.A [Enable Undervoltage Alarm]	0	0~1	退出; 投入 OFF; ON
	低电压告警定值 LVP.A [Undervoltage Alarm value]	50V	1~200	
	低电压告警延时 LVP.A.T [Undervoltage Alarm delay]	5s	0~60	
	无流闭锁告警 E.LVPA.IB [Enable Undervoltage Alarm current block]	0	0~1	退出; 投入 OFF; ON [If enable LVP.IB, when the current is less than I.None, under voltage protection will be blocked.]
	PT 断线闭锁告警 E.A.PT.B [Enable PT break alarm block]	1	0~1	退出; 投入 OFF; ON [When PT break occurs, the relay will send an alarm signal and lock out the under voltage protection.]
	合位允许告警	0	0~1	退出; 投入

	E.CB OnA.B [Enable circuit breaker on Alarm block]			OFF; ON
	低压阈值告警 E.A.LVThr. [Enable Undervoltage Alarm threshold]	1	0~1	退出; 投入 OFF; ON [If enable LVTHr. , when the voltage is greater than U.None and less than U.LVP , under voltage protection will alarm. If exit E. A.LVTHr. , under voltage protection is Loss voltage protection.]
零序过压保护 U0.OVP [59N] [Residual overvoltage]	零序过压投退 E.U0.OVP [Enable Residual over voltage protection]	0	0~2	退出; 告警; 跳闸 OFF; Alarm; Trip
	零序过压定值 U0.OVP [Residual over voltage value]	20V	0~200	
	零序过压延时 U0.OVP.T [Residual over voltage protection delay]	5s	0~60	
过电压保护 OVP [59] [Overvoltage Protection]	过电压保护投退 E.OVP [Enable overvoltage protection]	0	0~2	退出; 告警; 跳闸 OFF; Alarm; Trip
	过电压保护定值 U. OVP [Overvoltage protection value]	120V	0~200	
	过电压告警延时 OVP.A.T [Overvoltage protection Alarm delay]	5s	0~999	
	过电压跳闸延时	5s	0~60	

	OVP.T.T [Overvoltage protection Trip delay]			
逆功率保护 RP [32R] [Directional power protection]	逆功率保护投退 E.RP [Enable Reverse-Power Protection]	0	0~1	退出; 投入 OFF; ON
	逆功率保护定值 RP [Reverse-Power Protection value]	0	0~ 1000000000	
	逆功率保护延时 RP.T [Reverse-Power Protection delay]	0	0~99	
高频保护 OF [81O] [Over Frequency Protection]	高频保护投退 E.OF [Enable Over Frequency]	0	0~1	退出; 投入 OFF; ON
	高频保护定值 OF [Over Frequency value]	50Hz	40~70	
	高频保护延时 OF.T [Over Frequency delay]	5s	0~999	
非电量 1 保护 Non-Electricity1 Protection	非电量 1 投退 E. Non-el1 [Enable Non-Electricity1]	0	0~1	退出; 投入 OFF; ON
	非电量 1 方式 E. Non-el1.M [Enable Non-Electricity1 Mode]	0	0~1	告警; 跳闸 Alarm; Trip
	非电量 1 延时 Non-el1.T [Non-Electricity1. delay]	1s	0~999	
非电量 2 保护 Non-Electricity2 Protection	非电量 2 投退 E. Non-el2 [Enable Non-Electricity2]	0	0~1	退出; 投入 OFF; ON
	非电量 2 方式	0	0~1	告警; 跳闸

	E. Non-el2.M [Enable Non-Electricity2 Mode]			Alarm; Trip
	非电量 2 延时 Non-el2.T [Non-Electricity2 delay]	1s	0~999	
检同期 [25] Synchro-Check	同期控制字 E.SameP. [Enable Synchro-Check]	0	0~1	退出; 投入 OFF; ON
	同期稳定延时 SameP.StaT [Synchro-Check Stabilization delay]	0.2s	0~999.999	
	同期对象类型 SameP.Type [Synchro-Check type]	1	0~1	差频(准同期合闸); 同频(环网合闸) Dif.Fr; Same.Fr [Differential Frequency;Same Frequency]
	系统侧通道号 Sy.CH [System Channel]	9	0~14	
	系统侧一次电压 SyPr.U [System Side Primary Voltage]	10kV	0~9999	
	系统侧 PT 一次值 SyPT.Pr [System Side PT Primary Voltage]	10kV	0~9999	
	系统侧 PT 二次值 SyPT.Se [System Side PT Secondary Voltage]	100V	0~9999	
	待并侧通道号 Gr.C.CH [Generator voltage Channel]	13	0~14	
	待并侧一次电压	10kV	0~9999	

	GrC.PriU [Generator Primary voltage]			
	待并侧 PT 一次值 GrC.PTPr [Generator PT Primary Voltage]	10kV	0~9999	
	待并侧 PT 二次值 GrC.PTSe [Generator PT Secondary Voltage]	100V	0~9999	
	允许正压差% Po.U.Di% [Poaitive voltage difference allowed]	5%	0~30	
	允许负压差% Ne.U.Di% [Negative voltage difference allowed]	5%	0~30	
	额定频率 Rated Fr [Rated Frequency]	50Hz	40~70	
	系统侧频率偏差 Sy.Fr.Di [System Frequency difference]	0.1Hz	0~5	
	待并侧频率偏差 GrC.FrDi [Generator Frequency difference]	0.1Hz	0~5	
	允许正频差 Po.Fr.Di [Positive Frequency difference allowed]	0.1Hz	0~5	
	允许负频差 Ne.Fr.Di [Negative Frequency diffrence]	0.1Hz	0~5	

	allowed]			
	允许频差加速度 Fr.Dif.A [Frequency difference accelation allowed]	1Hz/s	0~10	
	同频并网相角差 SaFr.PhD [Same Frequency Phase Angle difference]	5°	0~60	
	差频并网相角差 DiFr.PhD [Difference Frequency Phase Angle difference]	5°	0~60	
	系统侧相角补偿 Sys.Ph.C [System Phase Angle Compensation]	0°	0~330	
	同期导前时间 SameP.Le.T [Synchronism Lead Time]	0.1s	0.02~999	
	跳闸内部时间 Default.T [Trip Default Time]	0s	0~999	
	事故总信号延时 Acci.S.T [Accident Signal delay]	0.3s	0.01~60	
	断路器位置采集 CB Po.Ac [Circuit Breaker position Collection]	1	0~1	辅助触点; 分合位监视 Auxiliary.C;CB M. [Auxiliary contact;Circuit Breaker Monitor]
	断路器动作时间 Cir.Br.T [Circuit Breaker trip and close time]	0.3s	0~999	

	弹簧未储能延时 Sp.En.D. [Discharge delay]	0s	0~999	
	过量返回系数 Excess R.C [Excess Return Coefficient]	0.95	0.001~1	
	欠量返回系数 Under R.C [Under Return Coefficient]	1.05	1~2	
CT 断线告警 CT supervision[60]	CT 断线告警投退 E.CTBr.A [Enable CT Break Alarm]	0	0~1	退出；投入 OFF； ON
	CT 断线无流定值 CTBr.I.N [CT Break No-Current]	0.125A	0.04~100	
	CT 断线有流定值 CTBr.I.S [CT Break Current setting]	0.2A	0.04~100	
	CT 断线告警延时 CTBr.T [CT Break Alarm time]	5s	0~999	
检修状态闭锁 Over Haul-lockout	检修状态闭锁通讯投退 E. M.BC [Enable Overhaul-lockout communication]	0	0~1	退出；投入 OFF； ON
	检修状态闭锁出口投退 E. M.BE [Enable Overhaul-lockout DO]	0	0~1	退出；投入 OFF； ON
	跳闸展宽 Tripping pulse	0.3s	0~1	
	I0 参与 2CT 计算 I0 P 2CT [I0 participate in 2CT calculation]	0	0~ 1	保护 CT 不同变比;保护 CT 同变比 CT same;CT diff. [protective CT is different from zero

				sequence CT] ; [protective CT is same as zero sequence CT] [When there are 2CT, whether zero sequence current is involved in the calculation of Ib.]
--	--	--	--	---

AM5SE-T 定值表				
AM5SE-T Setting				
保护名称 Protection Name	定值名称 Value Name	默认值 Default	范围 Range	备注 Remark
	CT 变比 CT	20	0.1~9999	
	PT 变比 PT	100	0.1~9999	
	电压接线方式 PT Mode [Voltage measurement mode]	0	0~1	3PT; 2PT
	电流接线方式 CT Mode [Current measurement mode]	0	0~1	3CT; 2CT
	一次电压显示 U Unit [Primary voltage display]	0	0~1	kV;V
过流一段 3I>>> [50] [Instantaneous overcurrent]	过流一段投退 E.3I>>> [Enable.3I>>>]	0	0~1	退出; 投入 OFF; ON
	一段经复压 E.3I>>>.U2 [Enable.3I>>> .Composite Voltage]	0	0~1	退出; 投入 OFF; ON [If enable 3I>>>.U2, composite voltage conditions should be considered for

				overcurrent protection. When the smallest of the three line voltages is less than U.Under and greater than U.Less or the negative voltage greater than U2 the overcurrent protection DO is prepare work.]
	过流一段定值 3I>>> [3I>>> value]	10A	0.04~100	
	过流一段延时 3I>>>.T [3I>>> delay]	0s	0~60	
	过流二段投退 E.3I>> [Enable.3I>>]	0	0~1	退出; 投入 OFF; ON
过流二段 3I>> [51] [Time-limited overcurrent]	二段经复压 E.3I>>.U2 [Enable.3I>> .Composite Voltage]	0	0~1	退出; 投入 OFF; ON [If enable 3I>>>.U2,composite voltage conditions should be considered for overcurrent protection. When the smallest of the three line voltages is less than U.Under and greater than U.Less or the negative voltage greater than U2 the overcurrent protection DO is prepare work.]
	过流二段定值 3I>>	7.5A	0.04~100	

	[3I>> value]			
	过流二段延时 3I>>.T [3I>> delay]	1s	0~60	
	过流三段投退 E.3I> [3I> value]	0	0~1	退出; 投入 OFF; ON
过流三段 3I> [51] [Definite time overcurrent]	三段经复压 E.3I>.U2 [Enable.3I> .Composite Voltage]	0	0~1	退出; 投入 OFF; ON [If enable 3I>>>.U2, composite voltage conditions should be considered for overcurrent protection. When the smallest of the three line voltages is less than U.Under and greater than U.Less or the negative voltage greater than U2 the overcurrent protection DO is prepare work.]
	过流三段定值 3I> [3I> value]	7A	0.04~100	
	过流三段延时 3I>.T [3I> delay]	2s	0~60	
反时限过流 I>Inv. [51] [Inverse time overcurrent (IDMT)]	反时限过流投退 E.I>.Inv [Enable I> Inverse]	0	0~1	退出; 投入 OFF; ON
	反时限经复压 E. I>.Inv [Enable I>Inverse Composite Voltage]	0	0~1	退出; 投入 OFF; ON [If enable I>.Inv, composite voltage

				conditions should be considered for overcurrent protection. When the smallest of the three line voltages is less than U_{Under} and greater than U_{Less} or the negative voltage greater than U_2 the overcurrent protection DO is prepare work.]
	反时限启动电流 I>.Inv [Inverse current]	6A	0.04~100	
	反时限时间系数 I>.Inv.K [Inverse time coefficient]	0.1s	0~100	
	反时限曲线类型 I>.Inv.X [Inverse curves]	0	0~2	一般；非常；极端 NI；VI；EI
过负荷告警 I>Lo.A [49F] [Overload Alarm]	过负荷告警投退 E. I>Lo.A [Enable Overload Alarm]	0	0~1	退出；投入 OFF；ON
	过负荷告警定值 I>Lo.A [Overload Alarm value]	6A	0.04~100	
	过负荷告警延时 I>Lo.A.T [Overload Alarm delay]	5s	0~999	
过负荷跳闸 I>Lo.T [49F] Overload Trip]	过负荷跳闸投退 E.I>Lo.T [Enable Overload Trip]	0	0~1	退出；投入 OFF；ON
	过负荷跳闸定值 I>Lo.T [Overload Trip value]	7A	0.04~100	

	过负荷跳闸延时 I>Lo.T.T [Overload Trip delay]	10s	0~60	
I01 过流一段 I01>>> [50N] [Instantaneous ground fault overcurrent]	I01 一段投退 E. I01>>> [Enable I01>>>]	0	0~1	退出; 投入 OFF; ON
	I01 一段定值 I01>>> [I01>>> value]	10A	0.04~100	
	I01 一段延时 I01>>>.T [I01>>> delay]	5s	0~60	
I01 过流二段 I01>> [51N] [Time limited ground fault overcurrent]	I01 二段投退 E. I01>> [Enable I01>>]	0	0~2	退出; 告警; 跳闸 OFF; Alarm; Trip
	I01 二段定值 I01>> [I01>>>value]	9A	0.04~100	
	I01 二段延时 I01>>.T [I01>> delay]	10s	0~60	
I01 反时限过流 I01.Inv [51N] [Inverse time ground fault]	I01 反时限投退 E. I01.Inv [Enable I01.Inv]	0	0~1	退出; 投入 OFF; ON
	I01 反时限启动电流 I01.Inv [I01 Inverse current]	6A	0.04~100	
	I01 反时限时间系数 I01.Inv.K [I01 Inverse time coefficient]	0.1s	0~100	
	I01 反时限曲线类型 I01.Inv.X [I01 Inverse curves]	0	0~2	一般; 非常; 极端 NI; VI; EI
I02 过流一段 I02>>>	I02 一段投退 E.I02>>>	0	0~1	退出; 投入 OFF; ON

[50N]	[Enable I02>>>]			
[Instantaneous ground fault overcurrent]	I02 一段定值 I02>>> [I02>>> value]	10A	0.04~100	
	I02 一段延时 I02>>>.T [I02>>> delay]	5s	0~60	
I02 过流二段 I02>> [51N]	I02 二段投退 E. I02>> [Enable I02>>]	0	0~2	退出; 告警; 跳闸 OFF; Alarm; Trip
[Time limited ground fault overcurrent]	I02 二段定值 I02>> [I02>>>value]	9A	0.04~100	
	I02 二段延时 I02>>.T [I02>> delay]	5s	0~60	
I02 反时限过流 I02.Inv [51N]	I02 反时限投退 E.I02.Inv. [Enable I02.Inv]	0	0~1	退出; 投入 OFF; ON
[Inverse time ground fault]	I02 反时限启动电流 I02.Inv [I02 Inverse current]	6A	0.04~100	
	I02 反时限时间系数 I02.Inv.K [I02 Inverse time coefficient]	0.1s	0~100	
	I02 反时限曲线类型 I02.Inv.X [I02 Inverse curves]	0	0~2	一般; 非常; 极端 NI; VI; EI
PT 断线告警 PT supervision[60]	PT 断线告警投退 E.PtBr.A [Enable PT Break alarm]	0	0~1	退出; 投入 OFF; ON
	PT 断线告警延时 PtBr.T [PT Break delay]	5s	0~999	
	无压定值	15V	0~200	[Less than U.None

	U.None [No-voltage]			means that there is no voltage]
	无流定值 I.None [No-current]	0.2A	0.04~100	[Less than I.None means that there is no current]
	PT 断线负序电压 U2.Pt [Negative sequence voltage]	35V	1~200	
控故障告警 Trip and close circuit supervision	控故障告警投退 E.CB.A [Enable Trip and close circuit supervision alarm]	0	0~1	退出；投入 OFF；ON
	控故障告警延时 CB.A.T [Trip and close circuit supervision alarm delay]	10s	0~999	
	低压阈值 U. Less [Under voltage threshold]	15V	0~200	复合电压判据 Composite voltage criterion
	低电压定值 U. Under [Under voltage value]	70V	0~200	
	复合电压负序定值 U2 [Negative voltage value]	35V	0~200	
轻瓦斯告警 LGas. [Light Gas Alarm]	轻瓦斯告警投退 E.LGas.A [Enable Light Gas.Alarm]	0	0~1	退出；投入 OFF；ON
	轻瓦斯告警延时 LGas.T [Light Gas Alarm delay]	1s	0~999	
重瓦斯跳闸 SGas [Heavy Gas Trip]	重瓦斯跳闸投退 E.SGas.T [Enable Heavy Gas Trip]	0	0~1	退出；投入 OFF；ON
	重瓦斯跳闸延时	1s	0~60	

	SGas.T [Heavy Gas Trip. delay]			
压力释放 Pre.Re [Pressure Release]	压力释放投退 E. Pre.Re [Enable Pressure Release]	0	0~2	退出; 告警; 跳闸 OFF; Alarm; Trip
	压力释放延时 Pre.Re.T [Pressure Release delay]	1s	0~60	
高温告警 OTem [Over temperature Alarm]	高温告警投退 E.OTem.A [Enable Over temperature Alarm]	0	0~1	退出; 投入 OFF; ON
	高温告警延时 OTem.T [Over temperature Alarm delay]	1s	0~999	
超温跳闸 HTem. [High temperature Trip]	超温跳闸投退 E.HTem.T [Enable High temperature Trip]	0	0~1	退出; 投入 OFF; ON
	超温跳闸延时 HTem.T [High temperature Trip delay]	1s	0~60	
变压器门误开 DoOp. [Transformer Door Opening Protection]	门开投退 E.DoOp. [Enable Transformer Door Opening]	0	0~2	退出; 告警; 跳闸 OFF; Alarm; Trip
	门开延时 DoOp.T [Transformer Door Opening delay]	1s	0~60	
温控器故障 E.Th.Fa. [Thermostat Failure]	温控器故障投退 E.Th.Fa. [Enable Thermostat Failure]	0	0~2	退出; 告警; 跳闸 OFF; Alarm; Trip

Protection]	温控器故障延时 Th.Fa.T [Thermostat Failure delay]	1s	0~60	
非电量 1 保护 Non-Electricity1 Protection	非电量 1 投退 E.Non-el1 [Enable Non-Electricity1]	0	0~2	退出; 告警; 跳闸 OFF; Alarm; Trip
	非电量 1 延时 Non-el1.T [Non-Electricity1 delay]	1s	0~60	
非电量 2 保护 Non-Electricity2 Protection	非电量 2 投退 E. Non-el2 [Enable Non-Electricity2]	0	0~2	退出; 告警; 跳闸 OFF; Alarm; Trip
	非电量 2 延时 Non-el2.T [Non-Electricity2 delay]	1s	0~60	
负序过流一段跳闸 I2>>> Trip [46] [Negative sequence instantaneous overcurrent]	负序一段投退 E. I2>>>T [Enable I2>>> Trip]	0	0~1	退出; 投入 OFF; ON
	I2 一段跳闸定值 I2>>>T [I2>>> Trip value]	10A	0.04~100	
	I2 一段跳闸延时 I2>>>T.T [I2>>>Trip delay]	2s	0~60	
负序过流一段告警 I2>>> Alarm [46] [Negative sequence instantaneous overcurrent]	I2 一段告警投退 E. I2>>>A [Enable I2>>> Alarm]	0	0~1	退出; 投入 OFF; ON
	I2 一段告警定值 I2>>>A [I2>>> Alarm value]	10A	0.04~100	
	I2 一段告警延时 I2>>>A.T [I2>>>Alarm delay]	1s	0~60	
负序过流二段跳闸 I2>>Trip	I2 二段跳闸投退 E. I2>>T	0	0~1	退出; 投入 OFF; ON

[46] [Negative sequence time-limited overcurrent]	[Enable I2>> Trip]			
	I2 二段跳闸定值 I2>>T [I2>> Trip value]	9A	0.04~100	
	I2 二段跳闸延时 I2>>T.T [I2>>Trip delay]	4s	0~999	
负序过流二段告警 I2>>Alarm [46] [Negative sequence time-limited overcurrent]	I2 二段告警投退 E.I2>>A [Enable I2>> Alarm]	0	0~1	退出; 投入 OFF; ON
	I2 二段告警定值 I2>>A [I2>> Alarm value]	9A	0.04~100	
	I2 二段告警延时 I2>>A.T [I2>>Alarm delay]	3s	0~999	
负序反时限保护 I2>Inv [46] [Negative sequence inverse overcurrent (IDMT)]	负序反时限投退 E. I2>Inv [Enable I2>Inverse]	0	0~1	退出; 投入 OFF; ON
	负序反时限电流 I2>Inv [I2>Inverse value]	6A	0.04~100	
	负序反时限系数 I2>Inv.K [I2>Inverse time coefficient]	0.1s	0~100	
	负序反时限曲线 I2>Inv.X [I2>Inverse curves]	0	0~2	一般; 非常; 极端 NI; VI; EI
FC 配合的过流闭锁 功能 FC Block	FC 闭锁投退 E. FCBlock [Enable FC Block]	0	0~1	退出; 投入 OFF; ON [When the fault current is greater than FCBlock.I, the relay's DO will be blocked,in order to ensure that the fuse is first blown.]
	FC 闭锁电流定值 FCBlock.I	10A	0.04~75	

	[FC Block current value]			
	FC 闭锁延时 FCBlock.T [FC Block delay]	5s	0~60	
	事故总信号延时 Acci.S.T [Accident Signal delay]	0.3s	0~60	
	内部延时 Default.T [Default delay]	0s	0~60	
	断路器位置采集 CB Po.Ac [Circuit Breaker position Collection]	1	0~1	辅助触点; 分合位监视 Auxiliary.C;CB M. [Auxiliary contact;Circuit Breaker Monitor]
	断路器动作时间 Cir.Br.T [Circuit breaker trip and close time]	0.3s	0~999	
	弹簧未储能延时 Sp.En.D. [Discharge delay]	0s	0~999	
	过量返回系数 Excess R.C [Excess Return Coefficient]	0.95	0.001~1	
	欠量返回系数 Under R.C [Under Return Coefficient]	1.05	1~2	
CT 断线告警 CT supervision[60]	CT 断线告警投退 E.CTBr.A [Enable CT Break Alarm]	0	0~1	退出; 投入 OFF; ON
	CT 断线无流定值 CTBr.I.N [CT Break No-Current]	0.125A	0.04~100	
	CT 断线有流定值 CTBr.I.S [CT Break Current setting]	0.2A	0.04~100	

	CT 断线告警延时 CTBr.T [CT Break Alarm time]	5s	0~999	
零序过压保护 U0.OVP [59N] [Residual over voltage]	零序过压投退 E.U0.OVP [Enable Residual over voltage protection]	0	0~2	退出；告警；跳闸 OFF； Alarm； Trip
	零序过压定值 U0.OVP [Residual over voltage value]	20V	0~200	
	零序过压延时 U0.OVP.T [Residual over voltage protection delay]	5s	0~60	
检修状态闭锁 Over Haul-lockout	检修状态闭锁通讯投退 E. M.BC [Enable Overhaul-lockout communication]	0	0~1	退出；投入 OFF； ON
	检修状态闭锁出口投退 E. M.BE [Enable Overhaul-lockout DO]	0	0~1	退出；投入 OFF； ON
	跳闸展宽 Tripping pulse	0.3s	0~1	
	I0 参与 2CT 计算 I0 P 2CT [I0 participate in 2CT calculation]	0	0~ 1	保护 CT 不同变比；保护 CT 同变比 CT same;CT diff. [protective CT is different from zero sequence CT] ; [protective CT is same as zero sequence CT] [When there are 2CT, wheather zero sequence current is involved in the calculation of Ib.]

AM5SE-M 定值表				
AM5SE-M Setting				
保护名称 Protection Name	定值名称 Value Name	默认值 Default	范围 Range	备注 Remark
	CT 变比 CT	300	0.1~9999	
	PT 变比 PT	100	0.1~9999	
	电压接线方式 PT Mode [Voltage measurement mode]	0	0~1	3PT; 2PT
	电流接线方式 CT Mode [Current measurement mode]	0	0~1	3CT; 2CT
	一次电压显示 U Unit [Primary voltage display]	0	0~1	kV; V
	额定电流一次值 Ie1 [Rated primary current]	300A	0.04~9999	
	电动机额定启动时间 Te [Rated start time of motor]	5	0~9999	
	启动延时 Start Delay	0.04s	0~10	
启动时过流一段 3I>>>.S [50] [Instantaneous Overcurrent of Starting]	过流一段投退 E.3I>>> [Enable.3I>>>]	0	0~1	退出; 投入 OFF; ON
	启动一段定值 3I>>>.S [3I>>> value of Starting]	30A	0.04~100	
	启动一段延时 3I>>>.Ts [3I>>>.start delay]	0s	0~60	
运行时过流一段	运行一段定值	15A	0.04~100	

3I>>>.R [50] [Instantaneous Overcurrent of Running]	3I>>>.R [3I>>> value of Running]			
	运行一段延时 3I>>>.Tr [3I>>>.Running delay]	0s	0~60	
过流二段 3I>> [51] [Time-limited overcurrent]	过流二段投退 E.3I>> [Enable.3I>>]	0	0~1	退出；投入 OFF；ON
	过流二段定值 3I>> [3I>> value]	2A	0.04~100	
	过流二段延时 3I>>.T [3I>> delay]	2s	0~60	
反时限过流 I>.Inv. [51] [Inverse time overcurrent (IDMT)]	反时限过流投退 E.I>.Inv [Enable I> Inverse]	0	0~1	退出；投入 OFF；ON
	反时限启动电流 I>.Inv [Inverse current]	6A	0.04~100	
	反时限时间系数 I>.Inv.K [Inverse time coefficient]	0.1s	0~100	
	反时限曲线类型 I>.Inv.X [Inverse curves]	0	0~2	一般；非常；极端 NI；VI；EI
过负荷告警 I>Lo.A [49F] [Overload Alarm]	过负荷告警投退 E. I>Lo.A [Enable Overload Alarm]	0	0~1	退出；投入 OFF；ON
	过负荷告警定值 I>Lo.A [Overload Alarm value]	6A	0.04~100	
	过负荷告警延时 I>Lo.A.T [Overload Alarm delay]	5s	0~999	
过负荷跳闸 I>Lo.T [49F] [Overload Trip]	过负荷跳闸投退 E.I>Lo.T [Enable Overload Trip]	0	0~1	退出；投入 OFF；ON
	过负荷跳闸定值	7A	0.04~100	

	I>Lo.T [Overload Trip value]			
	过负荷跳闸延时 I>Lo.T.T [Overload Trip delay]	10s	0~60	
启动时间过长 E.SoutT [48] [Motor Start time supervision]	启动超时投退 E.SoutT [Enable Start out time]	0	0~1	退出；投入 OFF； ON
	启动超时定值 SoutT.I [Start out time delay]	1.125	0.04~100	
堵转保护 [51LR] Locked rotor	堵转保护投退 E.Stall [Enable locked rotor]	0	0~1	退出；投入 OFF； ON
	堵转电流定值 Stall.I [Locked rotor Current value]	6.5A	0.04~100	
	堵转保护延时 Stall.T [Locked rotor delay]	5s	0~60	
I01 过流一段 I01>>> [50N] [Instantaneous ground fault overcurrent]	I01 一段投退 E. I01>>> [Enable I01>>>]	0	0~1	退出；投入 OFF； ON
	I01 一段定值 I01>>> [I01>>> value]	5A	0.04~100	
	I01 一段延时 I01>>>.T [I01>>> delay]	1s	0~60	
I01 过流二段 I01>> [51N] [Time limited ground fault overcurrent]	I01 二段投退 E. I01>> [Enable I01>>]	0	0~2	退出；告警；跳闸 OFF； Alarm； Trip
	I01 二段定值 I01>> [I01>>>value]	3A	0.04~100	

	I01 二段延时 I01>>.T [I01>> delay]	2s	0~60	
负序过流一段 I2>>> [46] [Negative sequence instantaneous overcurrent]	负序一段投退 E. I2>>> [Enable I2>>>]	0	0~1	退出; 投入 OFF; ON
	负序一段定值 I2>>> [I2>>> value]	10A	0.04~100	
	负序一段延时 I2>>>.T [I2>>> delay]	5s	0~60	
负序过流二段 I2>> [46] [Negative sequence time-limited overcurrent]	负序二段投退 E. I2>> [Enable I2>>]	0	0~1	退出; 投入 OFF; ON
	负序二段定值 I2>> [I2>> value]	9A	0.04~100	
	负序二段延时 I2>>.T [I2>> delay]	10s	0~999	
负序反时限过流 I2>Inv [46] [Negative sequence inverse overcurrent(IDMT)]	负序反时限投退 E. I2>Inv [Enable I2>Inverse]	0	0~1	退出; 投入 OFF; ON
	负序反时限电流 I2>Inv [I2>Inverse value]	6A	0.04~100	
	负序反时限系数 I2>Inv.K [I2>Inverse. time coefficient]	0.1s	0~100	
	负序反时限曲线 I2>Inv.X [I2>Inverse curves]	0	0~2	一般; 非常; 极端 NI; VI; EI
热过载保护 [49M] Thermal overload	热过载投退 E. OverHeat [Enable thermal overload]	0	0~1	退出; 投入 OFF; ON
	告警百分比 Heat.A1.P [Thermal overload Alarm percentage]	70%	0~100	
	跳闸百分比	100%	0~200	

	Heat.Tr.P [Thermal overload Trip percentage]			
	发热时间常数 HeatPro.K [Thermal overload coefficient]	15min	0~100	
	散热时间常数 HeatEmi.K [Thermal overload emission coefficient]	30min	0~300	
	重启动过热闭锁值 HeatRe [Thermal overload Restart block]	50%	0~100	
低电压跳闸 LVP.T [27] [Undervoltage Trip]	低电压跳闸投退 E. LVP.T [Enable Undervoltage Trip]	0	0~1	退出；投入 OFF；ON
	低电压跳闸定值 LVP.T [Undervoltage Trip value]	50V	1~200	
	低电压跳闸延时 LVP.T.T [Undervoltage Trip delay]	5s	0~60	
	无流闭锁投退 E.LVPT.I.B [Enable Undervoltage Trip current block]	0	0~1	退出；投入 OFF；ON [If enable LVP.I.B, when the current is less than I.None, under voltage protection will be blocked.]
	PT 断线闭锁投退 E. T.PT.B [Enable PT break block trip]	1	0~1	退出；投入 OFF；ON [When PT break occurs, the relay will send an alarm signal and lock out the under voltage

				protection.]
	合位允许投退 E.CB.OnT.B [Enable circuit breaker on Trip block]	0	0~1	退出; 投入 OFF; ON
	低电压阈值投退 E. T.LVTHr. [Enable Undervoltage Trip threshold]	1	0~1	退出; 投入 OFF; ON [If enable LVTHr. , when the voltage is greater than U.None and less than U.LVP , under voltage protection will act. If exit LVTHr. , under voltage protection is Loss voltage protection.]
低电压告警 LVP.A [27] [Undervoltage Alarm]	低电压告警投退 E.LVP.A [Enable Undervoltage Alarm]	0	0~1	退出; 投入 OFF; ON
	低电压告警定值 LVP.A [Undervoltage Alarm value]	50V	1~200	
	低电压告警延时 LVP.A.T [Undervoltage Alarm delay]	5s	0~60	
	无流闭锁告警 E.LVPA.I.B [Enable Undervoltage Alarm current block]	0	0~1	退出; 投入 OFF; ON [If enable LVPI.B, when the current is less than I.None, under voltage protection will be blocked.]
	PT 断线闭锁告警 E.A.PT.B [Enable PT break block alarm]	1	0~1	退出; 投入 OFF; ON [When PT break occurs, the relay will send an alarm signal and lock out

				the under voltage protection.]
	合位允许告警 E.CB OnA.B [Enable circuit breaker on Alarm block]	0	0~1	退出; 投入 OFF; ON
	低压阈值告警 E.A.LVThr. [Enable Undervoltage Alarm threshold]	1	0~1	退出; 投入 OFF; ON [If enable LVThr., when the voltage is greater than U.None and less than U.LVP , under voltage protection will alarm. If exit LVThr. , under voltage protection is Loss voltage protection.]
零序过压保护 U0 OVP [59N] [Residual over voltage]	零序过压投退 E.U0.OVP [Enable Residual over voltage protection]	0	0~2	退出; 告警; 跳闸 OFF; Alarm; Trip
	零序过压定值 U0.OVP [Residual over voltage value]	120V	0~200	
	零序过压延时 U0.OVP.T [Residual over voltage protection delay]	10s	0~999	
PT 断线告警 PT supervision[60]	PT 断线告警投退 E.PtBr.A [Enable PT Break alarm]	0	0~1	退出; 投入 OFF; ON
	PT 断线告警延时 PtBr.T [PT Break delay]	10s	0~999	
	无压定值 U.None [No-voltage]	15V	0~200	[Less than U.None means that there is no voltage]

	无流定值 I.None [No-current]	0.2A	0.04~100	[Less than I.None means that there is no current]
	PT 断线负序电压 U2.Pt [Negative sequence voltage]	35V	0~200	
控故障告警 Trip and close circuit supervision	控故障告警投退 E. CB.A [Enable Trip and close circuit supervision alarm]	0	0~1	退出; 投入 OFF; ON
	控故障告警延时 CB.A.T [Trip and close circuit supervision alarm delay]	10s	0~999	
非电量 1 保护 Non-Electricity1 Protection	非电量 1 投退 E.Non-el1 [Enable Non-Electricity1]	0	0~1	退出; 投入 OFF; ON
	非电量 1 延时 Non-el1.T [Non-Electricity1 delay]	2s	0~60	
非电量 2 保护 Non-Electricity2 Protection	非电量 2 投退 E. Non-el2 [Enable Non-Electricity2]	0	0~1	退出; 投入 OFF; ON
	非电量 2 延时 Non-el2.T [Non-Electricity2 delay]	2s	0~999	
FC 配合的过流闭锁 FC Block	FC 闭锁投退 E. FCBlock [Enable FC Block]	0	0~1	退出; 投入 OFF; ON [When the fault current is greater than FCBlock.I, the relay's DO will be blocked,in order to ensure that the fuse is first blown.]
	FC 闭锁电流定值	10A	0.04~120	

	FCBlock.I [FC Block current value]			
	FC 闭锁延时 FCBlock.T [FC Block delay]	5s	0~60	
电压不平衡保护 [60] Unbalance Voltage Protection	电压不平衡投退 E. Unb.V [Enable Unbalance Voltage]	0	0~1	退出; 投入 OFF; ON
	电压不平衡度 Unb.V.R. [Unbalance Voltage factor]	20%	0~100	
	电压不平衡值 Unb.V [Unbalance Voltage value]	30V	0~200	
	电压不平衡延时 Unb.V.T [Unbalance Voltage delay]	0.03s	0~100	
相序保护 Incorrect Phase Protection	相序保护投退 E. Ph.Se. [Enable Staggered Phase]	0	0~1	退出; 投入 OFF; ON
	线电压高定值 LiV.HSet. [Line voltage high setting]	120V	0~200	
	线电压低定值 LiV.LSet. [Line voltage low setting]	70V	0~200	
	正序电压比例 U1 Ratio [Positive voltage Ratio]	30%	0~100	
	负序电压比例 U2 Ratio [Negative voltage Ratio]	50%	0~100	
	相序保护延时 Ph.Se.T [Staggered Phase delay]	0s	0~100	
	相序信号返回 T	2s	0~60	

	Ph.Se.SRT [Staggered Phase signal reset]			
电压断相保护 Voltage Phase Break Protection	电压断相投退 E.Ph.Br [Enable Voltage Phase Break]	0	0~1	退出; 投入 OFF; ON
	电压断相延时 Ph.Br.T [Voltage Phase Break delay]	5s	0~60	
	断相最大电压定值 Ph.BrUmax [Maximum Voltage of Phase Break]	30V	0~200	
	断相最小电压定值 Ph.BrUmin [Minimum Voltage of Phase Break]	18V	0~200	
	断相电压差值 Ph.BrU.Dif [Phase Break differential Voltage]	18V	0~200	
过电压保护 OVP [59] [Overvoltage Protection]	过电压保护投退 E.OVP [Enable Overvoltage]	0	0~2	退出; 告警; 跳闸 OFF; Alarm; Trip
	过电压保护定值 U.OVP [Overvoltage value]	120V	0~200	
	过电压保护延时 OVP.T [Overvoltage delay]	5s	0~60	
电流不平衡 Unb.I [60] Unbalance Current Protection	电流不平衡投退 E.Unb.I [Enable Unbalance Current]	0	0~2	退出; 告警; 跳闸 OFF; Alarm; Trip
	电流不平衡定值 Unb.I [Unbalance Current value]	15%	0~200	
	电流不平衡延时	5s	0~999	

	Unb.I.T [Unbalance Current delay]			
	事故总信号投退 E.Acci.S [Enable Accident Signal]	1	0~1	退出; 投入 OFF; ON
	事故总信号延时 Acci.S.T [Accident Signal delay]	0.3s	0~60	
	断路器位置采集 CB Po.Ac [Circuit Breaker position Collection]	1	0~1	辅助触点; 分合位监视 Auxiliary.C;CB M. [Auxiliary contact;Circuit Breaker Monitor]
	断路器动作时间 Cir.Br.T [Circuit Breaker trip and close time]	0.3s	0~999	
	弹簧未储能延时 Sp.En.D. [Discharge delay]	0s	0~999	
I01 反时限过流 I01.Inv [51N] [Inverse time ground fault]	I01 反时限投退 E.I01.Inv [Enable I01.Inv]	0	0~1	退出; 投入 OFF; ON
	I01 反时限启动电流 I01.Inv [I01 Inverse current]	6A	0.04~100	
	I01 反时限时间系数 I01.Inv.K [I01 Inverse time coefficient]	0.1s	0~100	
	I01 反时限曲线类型 I01.Inv.X [I01 Inverse curves]	0	0~2	一般; 非常; 极端 NI; VI; EI
I02 过流一段 I02>>>> [50N] [Instantaneous	I02 一段投退 E. I02>>>> [Enable I02>>>>]	0	0~1	退出; 投入 OFF; ON
	I02 一段定值	10A	0.04~100	

ground fault overcurrent]	I02>>> [I02>>> value]			
	I02 一段延时 I02>>>.T [I02>>> delay]	5s	0~60	
I02 过流二段 I02>> [51N] [Time limited ground fault overcurrent]	I02 二段投退 E. I02>> [Enable I02>>]	0	0~2	退出; 告警; 跳闸 OFF; Alarm; Trip
	I02 二段定值 I02>> [I02>>>value]	9A	0.04~100	
	I02 二段延时 I02>>.T [I02>> delay]	5s	0~60	
I02 反时限过流 I02.Inv. [51N] [Inverse time ground fault]	I02 反时限投退 E.I02.Inv. [Enable I02.Inv]	0	0~1	退出; 投入 OFF; ON
	I02 反时限启动电流 I02.Inv [I02 Inverse current]	6A	0.04~100	
	I02 反时限时间系数 I02.Inv.K [I02 Inverse time coefficient]	0.1s	0~100	
	I02 反时限曲线类型 I02.Inv.X [I02 Inverse curves]	0	0~2	一般; 非常; 极端 NI; VI; EI
	过量返回系数 Excess R.C [Excess Return Coefficient]	0.95	0.001~1	
	欠量返回系数 Under R.C [Under Return Coefficient]	1.05	1~2	
CT 断线告警 CT supervision[60]	CT 断线告警投退 E.CTBr.A [Enable CT Break Alarm]	0	0~1	退出; 投入 OFF; ON
	CT 断线无流定值	0.125A	0.04~100	

	CTBr.I.N [CT Break No-Current]			
	CT 断线有流定值 CTBr.I.S [CT Break Current setting]	0.2A	0.04~100	
	CT 断线告警延时 CTBr.T [CT Break Alarm time]	5s	0~999	
检修状态闭锁 Over Haul-lockout	检修状态闭锁通讯投退 E. M.BC [Enable Overhaul-lockout communication]	0	0~1	退出; 投入 OFF; ON
	检修状态闭锁出口投退 E. M.BE [Enable Overhaul-lockout DO]	0	0~1	退出; 投入 OFF; ON
	跳闸展宽 Tripping pulse	0.3s	0~1	
	I0 参与 2CT 计算 I0 P 2CT [I0 participate in 2CT calculation]	0	0~ 1	保护 CT 不同变比; 保护 CT 同变比 CT same;CT diff. [protective CT is different from zero sequence CT] ; [protective CT is same as zero sequence CT] [When there are 2CT, wheather zero sequence current is involved in the calculation of Ib.]

AM5SE-B 定值表 AM5SE-B Setting				
保护名称 Protection Name	定值名称 Value Name	默认值 Default	范围 Range	备注 Remark
	PT 变比 PT	100	0.1~9999	
	CT 变比 CT	50	0.1~9999	

	一次图显示方式 Pri.Sys. [Primary system display]	0	0~4	方式 0-方式 4 Mode0~4
	一次电压显示 U Unit [Primary voltage display]	0	0~1	KV; V
	电压接线方式 PT Mode [Voltage measurement mode]	1	0~1	3PT; 2PT
	电流接线方式 CT Mode [Current measurement mode]	0	0~1	3CT; 2CT
	1QF 位置 1QF On [1QF circuit breaker on]	8	1~16	
	2QF 位置 2QF On [2QF circuit breaker on]	9	1~16	
进线/母联备投 Standby Power Automatic Transfer	备投判进线电压控制字 E.In.V.C [Enable Incoming voltage control]	0	0~1	退出; 投入 OFF; ON
	备投方式 Spa.Mode [Spare mode]	0	0~4	退出; 分段备投; 进线备投; 自适应备投; 联切备投 OFF; Bus Standby; Incoming Standby; Self-adapt Standby; Joint Cut Standby
	进线 1 备投投退 E.1-In.Spa. [Enable 1-Incoming spare]	0	0~1	退出; 投入 OFF; ON
	进线 2 备投投退 E.2-In.Spa. [Enable 2-Incoming spare]	0	0~1	退出; 投入 OFF; ON
	4 路进线电压做备投 4U.S	0	0~1	退出; 投入 OFF; ON

[Enable 4-channel incoming voltage spare]			
分合指示灯关联 On OFF.I [Circuit Breaker On/Off indicator light]	0	0~2	分段柜;进线 1 柜;进线 2 柜 Busbar; 1-Incoming; 2-Incoming
进线 1 电流来源 I1 Source [1-Incoming current source]	0	0~2	通道 4; 通道 5; 通道 1 CH4;CH5;CH1
进线 2 电流来源 I2 Source [2-Incoming current source]	1	0~2	通道 4; 通道 5; 通道 1 CH4;CH5;CH1
零流来源 I0 Source	0	0~3	自产;外接通道 2; 外接通道 4; 外接通道 5 Self-produced; CH2; CH4; CH5
进线无压定值 In.U.None [Loss Incoming Voltage]	10V	0~200	
母线无压定值 B. U.None [Loss Bus Voltage]	10V	0~200	
进线有压定值 In.Vo.St.V [Incoming Voltage Store]	20V	0~200	
母线有压定值 B. Vo.St.V [Bus Voltage Store]	20V	0~200	
进线 1 无流定值 I1.None [1-Incoming Current none]	0.1A	0.04~100	
进线 2 无流定值 I2.None [2-Incoming Current none]	0.1A	0.04~100	
分段充电延时	15s	0~9999	

	B. Cha.D [Bus charge delay]			
	进线 1 充电延时 1-I.C.D [1-Incoming charge delay]	15s	0~9999	
	进线 2 充电延时 2-I.C.D [2-Incoming charge delay]	15s	0~9999	
	跳进线 1 延时 1-In.T.D. [1-Incoming Trip delay]	2s	0~9999	
	跳进线 2 延时 2-In.T.D. [2-Incoming Trip delay]	2s	0~9999	
	跳母联延时 Bus.T.D. [Bus Trip delay]	2s	0~9999	
	合进线 1 延时 1-In.C.D. [1-Incoming Close delay]	2s	0~9999	
	合进线 2 延时 2-In.C.D. [2-Incoming Close delay]	2s	0~9999	
	合母联延时 Bus.C.D. [Bus Close delay]	2s	0~9999	
	低压阈值 U. Less [Under Voltage threshold]	15V	0~200	
	低电压定值 U. Under [Under Voltage value]	70V	0~200	
	复合电压负序定值 U2 [Negative voltage value]	35V	0~200	

	无流定值 I.None [No-Current]	0.2A	0~100	[Less than I.None means that there is no current]
	无压定值 U.None [No-Voltage]	15V	0~200	[Less than U.None means that there is no voltage]
过流一段 3I>>> [50] [Instantaneous overcurrent]	过流一段投退 E.3I>>> [Enable.3I>>>]	0	0~1	退出; 投入 OFF; ON
	一段经复压 E.3I>>>.U [Enable.3I>>> .Composite Voltage]	0	0~1	退出; 投入 OFF; ON [If enable 3I>>>.U, composite voltage conditions should be considered for overcurrent protection. When the smallest of the three line voltages is less than U.Under and greater than U.Less, the overcurrent protection DO is prepare work.]
	一段带方向 E.3I>>>.D[67N] [Enable.3I>>> .direction]	0	0~1	不带方向; 指向线路; 指向母线 OFF;Line; Bus
	过流一段定值 3I>>> [3I>>> value]	6A	0.04~100	
	过流一段延时 3I>>>.T [3I>>> delay]	1s	0~99	
过流二段 3I>> [51] [Time-limited	过流二段投退 E.3I>> [Enable.3I>>]	0	0~1	退出; 投入 OFF; ON
	过流二段经复压闭锁	0	0~1	退出; 投入

overcurrent]	E.3I>>.U2 [Enable.3I>> .Composite Voltage]			OFF;ON [If enable 3I>>.U2, composite voltage conditions should be considered for overcurrent protection. When the smallest of the three line voltages is less than U.Under and greater than U.Less, the overcurrent protection DO is prepare work.]
	二段带方向 E.3I>>.D[67N] [Enable.3I>> .direction]	0	0~1	不带方向; 指向线路; 指 向母线 OFF;Line; Bus
	过流二段定值 3I>> [3I>> value]	5A	0.04~100	
	过流二段延时 3I>>.T [3I>> delay]	2s	0~99	
过流三段 3I> [51] [Definite time overcurrent]	过流三段投退 E.3I> [Enable.3I>]	0	0~1	退出; 投入 OFF; ON
	过流三段经复压闭锁 E.3I>.U2 [Enable.3I> .Composite Voltage]	0	0~1	退出; 投入 OFF; ON. [If enable 3I>.U2, composite voltage conditions should be considered for overcurrent protection. When the smallest of the three line voltages is less than U.Under and greater than U.Less, the overcurrent protection DO is prepare

				work.]
	三段带方向 E.3I>.D[67N] [Enable.3I> .direction]	0	0~1	不带方向；指向线路；指向母线 OFF; Line; Bus
	过流三段定值 3I> [3I> value]	5A	0.04~100	
	过流三段延时 3I>.T [3I> delay]	5s	0~99	
后加速过流 Post-Accelerated Overcurrent	后加速过流投退 E. I>P [Enable post-accelerated overcurrent]	0	0~1	退出；投入 OFF; ON
	后加速经复压 E. I>P.U [Enable I>P Composite Voltage]	0	0~1	退出；投入 OFF; ON [If enable I>P.U, composite voltage conditions should be considered for overcurrent protection. When the smallest of the three line voltages is less than U.Under and greater than U.Less, the overcurrent protection DO is prepare work.]
	后加速过流定值 I>P [Post-accelerated value]	4A	0.04~100	
	后加速过流延时 I>P.T [Post-accelerated delay]	1s	0~99	
I0 过流一段 I0>>> [50N] [Instantaneous ground fault overcurrent]	I0 一段投退 E. I0>>> [Enable I0>>>]	0	0~2	退出；告警；跳闸 OFF; Alarm; Trip
	I0 一段带方向 I0>>>D[67N] [Enable.I0>>> .direction]	0	0~2	不带方向；指向线路；指向母线 OFF;Line;Bus

	I0 一段定值 I0>>> [I0>>> value]	5A	0.04~100	
	I0 一段延时 I0>>>.T [I0>>> delay]	5s	0~99	
	I0 一段 3U0 值 I0>>>.3U0 [I0>>>.self-produced U0]	2V	0~200	
I0 过流二段 I0>> [51N] [Time limited ground fault overcurrent]	I0 二段投退 E. I0>> [Enable I0>>]	0	0~2	退出；告警；跳闸 OFF; Alarm; Trip
	I0 二段带方向 E. I0>>D[67N] [Enable.I0>>> .direction]	0	0~2	不带方向；指向线路；指 向母线 OFF;Line;Bus
	I0 二段定值 I0>> [I0>> value]	5A	0.04~100	
	I0 二段延时 I0>>.T [I0>> delay]	5s	0~99	
	I0 二段 3U0 值 I0>>.3U0 [I0>>.self-produced U0]	2V	0~200	
I0 后加速 I0 Post-Accelerated Overcurrent	I0 后加速投退 E. I0>P [Enable I0 post-accelerated overcurrent]	0	0~1	退出；投入 OFF; ON
	I0 后加速定值 I0>P [I0 Post-accelerated value]	5A	0~100	
	I0 后加速延时 I0>P.T [I0 Post accelerated delay]	5s	0~99	
母线充电保护	母线充电保护投退	0	0~1	退出；投入

Bus Charging Protection	E. B.Cha. [Enable Bus Charging Protection]			OFF; ON
	充电保护电流定值 B. Cha. [Bus Charging value]	5A	0~100	
	充电保护作用时间 Cha.Ac.T [Bus Charging action time]	3s	0~60	
	充电保护延时 B. Cha.T [Bus Chaeking delay]	5s	0~60	
反时限过流 I>.Inv [51] [Inverse time overcurrent (IDMT)]	反时限过流投退 E. I>.Inv [Enable I> Inverse]	0	0~1	退出; 投入 OFF; ON
	反时限经复压 E. I>.Inv.U2 [Enable I>Inverse Composite Voltage]	0	0~1	退出; 投入 OFF; ON [If enable I>.Inv.U, composite voltage conditions should be considered for overcurrent protection.When the smallest of the three line voltages is less than U.Under and greater than U.Less, the overcurrent protection DO is prepare work.]
	反时限启动电流 I>.Inv [Inverse current]	5A	0.04~100	
	反时限时间系数 I>.Inv.K [Inverse time coefficient]	0.5s	0.1~100	
	反时限曲线类型 I>.Inv.X [Inverse curves]	0	0~2	一般; 非常; 极端 S1;S2;S3

重合闸 [79] Auto-Recloser function	重合闸投退 E.Reclose [Enable Auto-Reclose]	0	0~1	退出；投入 OFF； ON
	重合闸延时 Reclose.T [Auto-Reclose delay]	5s	0~9999.999	
	重合闸方式 Reclose.X [Auto-reclose Mode]	0	0~1	不检；检无压 Not Check;Check
	重合闸充电延时 Rec.C.T [Auto-reclose charge delay]	15s	0~9999.999	
	重合闸充电返回 T RecC.RT [Auto-reclose charge return time]	15s	0~9999.999	
	不对应重合投退 E. nonP. [Enable non-position auto-reclose]	0	0~1	退出；投入 OFF； ON
过负荷联切 I>Lo.T [49F] [Overload Trip]	过负荷联切投退 E.I>Lo.T [Enable Overload Trip]	0	0~1	退出；投入 OFF； ON
	过负荷联切定值 I>Lo.T [Enable Overload Trip value]	5A	0~100	
	过负荷联切延时 I>Lo.T.T [Enable Overload Trip delay]	5s	0~99	
过负荷告警 I>Lo.A [49F] [Overload Alarm]	过负荷告警投退 E.I>Lo.A [Enable Overload Alarm]	0	0~1	退出；投入 OFF； ON
	过负荷告警定值 I>Lo.A [Enable Overload Alarm value]	5A	0~100	

	过负荷告警延时 I>Lo.A.T [Enable Overload Alarm delay]	5s	0~99	
控故障告警 Trip and close circuit supervision	控故障告警投退 E.CB.A [Enable Trip and close circuit supervision alarm]	0	0~1	退出; 投入 OFF; ON
	控故障告警延时 CB.A.T [Trip and close circuit supervision alarm delay]	5s	0~999	
母线 PT 断线 Bus PT supervision	母线 PT 断线控制字 E.BPtBr.A [Enable Bus PT Break]	0	0~1	退出; 投入 OFF; ON
	母线 PT 断线延时 BPtBr.T [Bus PT Break delay]	5s	0~999	
	EMC 闭锁投退 E.EMC.B [Enable EMC Block]	1	0~1	退出; 投入 OFF; ON
	内部延时 Default.T [Default Time]	0s	0~60	
	事故总信号延时 Acci.S.T [Accident signal delay]	0.3s	0~999	
检同期 [25] Synchro-Check	同期控制字 E.SameP. [Enable Synchro-Check]	0	0~1	退出; 投入 OFF; ON
	同期稳定延时 SameP.StaT [Synchro-Check Stabilization delay]	0.2s	0~999.999	
	同期对象类型 SameP.Type	1	0~1	差频(准同期合闸); 同频(环网合闸)

	[Synchro-Check type]			Dif.Fr; Same.Fr
	系统侧通道号 Sy.CH [System Channel]	13	0~14	
	系统侧一次电压 SyPr.U [System Side Primary Voltage]	10kV	0~9999	
	系统侧 PT 一次值 SyPT.Pr [System Side PT Primary Voltage]	10kV	0~9999	
	系统侧 PT 二次值 SyPT.Se [System Side PT Secondary Voltage]	100V	0~9999	
	待并侧通道号 Gr.C.CH [Generator voltage Channel]	14	0~14	
	待并侧一次电压 GrC.PriU [Generator Primary voltage]	10kV	0~9999	
	待并侧 PT 一次值 GrC.PTPr [Generator PT Primary Voltage]	10kV	0~9999	
	待并侧 PT 二次值 GrC.PTSe [Generator PT Secondary Voltage]	100V	0~9999	
	允许正压差% Po.U.Dif% [Poaitive voltage difference allowed]	5%	0~30	
	允许负压差% Ne.U.Dif%	5%	0~30	

	[Negative voltage difference allowed]			
	额定频率 Rated Fr [Rated Frequency]	50Hz	40~70	
	系统侧频率偏差 Sy.Fr.Di [System Frequency difference]	0.1Hz	0~5	
	待并侧频率偏差 GrC.FrDi [Generator Frequency difference]	0.1Hz	0~5	
	允许正频差 Po.Fr.Di [Positive Frequency difference allowed]	0.1Hz	0~5	
	允许负频差 Ne.Fr.Di [Negative Frequency difference allowed]	0.1Hz	0~5	
	允许频差加速度 Fr.Dif.A [Frequency difference accelation allowed]	1Hz/s	0~10	
	同频并网相角差 SaFr.PhD [Same Frequency Phase Angle difference]	5°	0~60	
	差频并网相角差 DiFr.PhD [Difference Frequency Phase Angle difference]	5°	0~60	
	系统侧相角补偿 Sys.Ph.C [System Phase Angle]	0°	0~330	

	Compensation]			
	同期导前时间 SameP.Le.T [Synchronism Lead Time]	0.1s	0.02~999	
	断路器动作时间 Cir.Br.T [Circuit Breaker trip and close time]	0.3s	0~999	
	弹簧未储能延时 Sp.En.D. [Discharge delay]	0s	0~999	
检修状态闭锁 Over Haul-lockout	检修状态闭锁通讯投退 E. M.BC [Enable Overhaul-lockout communication]	0	0~1	退出; 投入 OFF; ON
	检修状态闭锁出口投退 E. M.BE [Enable Overhaul-lockout DO]	0	0~1	退出; 投入 OFF; ON
	跳闸展宽 Tripping pulse	0.3s	0~1	
	I0 参与 2CT 计算 I0 P 2CT [I0 participate in 2CT calculation]	0	0~1	保护 CT 不同变比; 保护 CT 同变比 CT same;CT diff. [protective CT is different from zero sequence CT]; [protective CT is same as zero sequence CT] [When there are 2CT, wheather zero sequence current is involved in the calculation of Ib.]

AM5SE-C 定值表 AM5SE-C Setting				
保护名称 Protection Name	定值名称 Value Name	默认值 Default	范围 Range	备注 Remark
	CT 变比	300	0.1~9999	

	CT			
	PT 变比 PT	100	0.1~9999	
	电压接线方式 PT Mode [Voltage measurement mode]	0	0~1	3PT; 2PT
	电流接线方式 CT Mode [Current measurement mode]	0	0~1	3CT; 2CT
	一次电压显示 U Unit [Primary voltage display]	0	0~1	kV; V
过流一段 3I>>> [50] [Instantaneous overcurrent]	过流一段投退 E.3I>>> [Enable.3I>>>]	0	0~1	退出; 投入 OFF; ON
	过流一段定值 3I>>> [3I>>> value]	30A	0.04~100	
	过流一段延时 3I>>>.T [3I>>> delay]	0s	0~60	
过流二段 3I>> [51] [Time-limited overcurrent]	过流二段投退 E.3I>> [Enable.3I>>]	0	0~1	退出; 投入 OFF; ON
	过流二段定值 3I>> [3I>> value]	2A	0.04~100	
	过流二段延时 3I>>.T [3I>> delay]	2s	0~60	
反时限过流 I>.Inv. [51] [Inverse time overcurrent (IDMT)]	反时限过流投退 E. I>.Inv [Enable I> Inverse]	0	0~1	退出; 投入 OFF; ON
	反时限启动电流 I>.Inv	6A	0.04~100	

	[Inverse starting current]			
	反时限时间系数 I>.Inv.K [Inverse time coefficient]	0.5s	0~100	
	反时限曲线类型 I>.Inv.X [Inverse curves type]	0	0~2	一般；非常；极端 NI；VI；EI
I0 过流一段 I0>>> [50N] [Instantaneous ground fault overcurrent]	I0 过流一段投退 E. I0>>> [Enable I0>>>]	0	0~1	退出；投入 OFF；ON
	I0 过流一段定值 I0>>> [I0>>> value]	10A	0.04~100	
	I0 过流一段延时 I0>>>T [I0>>> delay]	5s	0~60	
I0 过流二段 I0>> [51N] [Time limited ground fault overcurrent]	I0 过流二段投退 I0>> [Enable I0>>]	0	0~2	退出；告警；跳闸 OFF；Alarm；Trip
	I0 过流二段定值 I0>> [I0>> value]	9A	0.04~100	
	I01 过流二段延时 I0>>T [I0>> delay]	10s	0~60	
欠电压保护 [27] Undervoltage Protection	欠电压保护投退 E.LVP [Enable Undervoltage]	0	0~2	退出；告警；跳闸 OFF；Alarm；Trip
	无流闭锁投退 E.LVP.NI.B [Enable Undervoltage none current block]	0	0~1	退出；投入 OFF；ON
	有流闭锁投退 E.LVP.I.B [Enable Undervoltage current block]	0	0~1	退出；投入 OFF；ON
	欠电压定值 U. LVP	70V	0~200	

	[Undervoltage value]			
	欠电压延时 LVP.T [Undervoltage delay]	5s	0~999	
	PT 断线闭锁投退 E. PT.B [Enable PT break block]	1	0~1	退出; 投入 OFF; ON
	合位允许投退 E.CB.On.B [Enable circuit breaker on block]	0	0~1	退出; 投入 OFF; ON
	低电压阈值投退 E. LVThr. [Enable Undervoltage threshold]	1	0~1	退出; 投入 OFF; ON
PT 断线告警 PT supervision[60]	PT 断线告警投退 E.PtBr.A [Enable PT Break alarm]	0	0~1	退出; 投入 OFF; ON
	PT 断线告警延时 PtBr.T [PT Break delay]	10s	0~999	
	无压定值 U.None [No-voltage]	15V	0~200	[Less than U.None means that there is no voltage]
	无流定值 I.None [No-current]	0.2A	0.04~100	[Less than I.None means that there is no current]
	PT 断线负序电压 U2.Pt [Negative sequence voltage]	35V	0~200	
控故障告警 Trip and close circuit supervision	控故障告警投退 E.CB.A [Enable Trip and close circuit supervision alarm]	0	0~1	退出; 投入 OFF; ON
	控故障告警延时 CB.A.T [Trip and close circuit	10s	0~999	

	supervision alarm delay]			
非电量 1 保护 Non-Electricity1 Protection	非电量 1 投退 E.Non-el1 [Enable Non-Electricity1]	0	0~1	退出; 投入 OFF; ON
	非电量 1 延时 Non-el1.T [Non-Electricity1 delay]	5s	0~60	
非电量 2 保护 Non-Electricity2 Protection	非电量 2 投退 E. Non-el2 [Enable Non-Electricity2]	0	0~1	退出; 投入 OFF; ON
	非电量 2 延时 Non-el2.T [Non-Electricity2 delay]	5s	0~999	
非电量 3 保护 Non-Electricity3 Protection	非电量 3 投退 E.Non-el3 [Enable Non-Electricity3]	0	0~1	退出; 投入 OFF; ON
	非电量 3 延时 Non-el3.T [Non-Electricity3. delay]	5s	0~999	
过电压保护 OVP [59] [Overvoltage Protection]	过电压保护投退 E.OVP [Enable Overvoltage]	0	0~2	退出; 告警; 跳闸 OFF; Alarm; Trip
	过电压保护定值 U.OVP [Overvoltage value]	120V	0~200	
	过电压保护延时 OVP.T [Overvoltage delay]	5s	0~999	
零序过压保护 U0.OVP [59N] [Residual over voltage]	U4 电压类型 U4 Type	0	0~2	外接零序电压; 自产零序电 压; 不平衡电压 U0; self-produced 3U0; Unbalance voltage
	零序过压投退 E.U0.OVP [Enable Residual over	0	0~1	退出; 投入 OFF; ON

	voltage protection]			
	零序过压定值 U0.OVP [Residual over voltage value]	120V	0~200	
	零序过压延时 U0.OVP.T [Residual over voltage protection delay]	10s	0~999	
不平衡电压保护 Unbalance Voltage Protection	不平衡电压投退 E.Unb.V [Enable Unbalance voltage]	0	0~1	退出; 投入 OFF; ON
	不平衡电压定值 Unb.V [Unbalance voltage value]	5V	0~200	
	不平衡电压延时 Unb.V.T [Unbalance Voltage delay]	0.03s	0~100	
电流不平衡 Unb.I [51C] [Capacitor bank unbalance Protection]	电流不平衡投退 E.Unb.I [Enable Unbalance Current]	0	0~1	退出; 投入 OFF; ON
	电流不平衡定值 Unb.I [Unbalance Current value]	5A	0.04~100	
	电流不平衡延时 Unb.I.T [Unbalance Current delay]	5s	0~60	
	事故总信号延时 Acci.S.T [Accident Signal delay]	0.3s	0.01~60	
	断路器位置采集 CB Po.Ac [Circuit Breaker position Collection]	1	0~1	辅助触点; 分合位监视 Auxiliary.C;CB M. [Auxiliary contact;Circuit Breaker Monitor]
	断路器动作时间 Cir.Br.T [Circuit Breaker trip and close time]	0.3s	0~999	

	弹簧未储能延时 Sp.En.D. [Discharge delay]	0s	0~999	
	过量返回系数 Excess R.C [Excess Return Coefficient]	0.95	0.001~1	
	欠量返回系数 Under R.C [Under Return Coefficient]	1.05	1~2	
过负荷告警 I>Lo.A [49] [Overload Alarm]	过负荷告警投退 E.I>Lo.A [Enable Overload Alarm]	0	0~1	退出；投入 OFF；ON
	过负荷告警定值 I>Lo.A [Overload Alarm value]	6A	0.04~100	
	过负荷告警延时 I>Lo.A.T [Overload Alarm delay]	5s	0~999	
过负荷跳闸 I>Lo.T [49] [Overload Trip]	过负荷跳闸投退 E.I>Lo.T [Enable Overload Trip]	0	0~1	退出；投入 OFF；ON
	过负荷跳闸定值 I>Lo.T [Overload Trip value]	7A	0.04~100	
	过负荷跳闸延时 I>Lo.T.T [Overload Trip delay]	10s	0~60	
CT 断线告警 CT supervision[60]	CT 断线告警投退 E.CTBr.A [Enable CT Break Alarm]	0	0~1	退出；投入 OFF；ON
	CT 断线无流定值 CTBr.I.N [CT Break No-Current]	0.125A	0.04~100	
	CT 断线有流定值 CTBr.I.S	0.2A	0.04~100	

	[CT Break Current setting]			
	CT 断线告警延时 CTBr.T [CT Break Alarm time]	5s	0~999	
检修状态闭锁 Over Haul-lockout	检修状态闭锁通讯投退 E. M.BC [Enable Overhaul-lockout communication]	0	0~1	退出; 投入 OFF; ON
	检修状态闭锁出口投退 E. M.BE [Enable Overhaul-lockout DO]	0	0~1	退出; 投入 OFF; ON
	跳闸展宽 Tripping pulse	0.3s	0~1	
	I0 参与 2CT 计算 I0 P 2CT [I0 participate in 2CT calculation]	0	0~ 1	保护 CT 不同变比; 保护 CT 同变比 [protective CT is different from zero sequence CT]; [protective CT is same as zero sequence CT] [When there are 2CT, wheather zero sequence current is involved in the calculation of Ib.]

AM5SE-MD 定值表 AM5SE-MD Setting				
保护名称 Protection Name	定值名称 Value Name	默认值 Default	范围 Range	备注 Remark
	电动机额定二次电流 Ie Ie [Rated Motor secondary current]	1A	0.04~120	
	电动机额定启动时间 Te Te [Rated Motor starting time]	5s	0~100000	
	电压接线方式	0	0~1	3PT; 2PT

	PT mode [Voltage measurement mode]			
	PT 额定一次值 Ue1 [Rated primary value]	110kV	0~100000	
	PT 额定二次值 Ue [Rated secondary value]	0.1kV	0~10000	
	首端 CT 额定一次值 Ie1.H [Head CT rated primary current]	100A	0~100000	
	首端 CT 额定二次值 Ie.H [Head CT rated secondary current]	5A	1~100	
	尾端 CT 额定一次值 Ie1.L [Tail CT rated primary current]	100A	0~100000	
	尾端 CT 额定二次值 Ie.L [Tail CT rated secondary current]	5A	1~100	
	零序电流来源 I0 Source	1	0~1	外接; 自产 I0; self-produced
	零序电压来源 U0 Source	1	0~1	外接; 自产 U0; self-produced
	无压定值 U.None [No-Voltage]	15V	0~200	
	无流定值 I.None [No-Current]	0.2A	0.04~100	
差动速断	差动速断投退	0	0~1	退出; 投入

[87M] Instantaneous Differential	E.Ins.Dif [Enable Instantaneous Differential]			OFF; ON
	差动速断定值 Ins.Dif [Instantaneous Differential value]	$8 * I_e$	$0.05 * I_e \sim 100 * I_e$	
比率差动 [87M] Differential protection with ratio restraining	比率差动投退 E.Dif.P.R [Enable Differential protection with ratio restraining]	0	0~1	退出; 投入 OFF; ON
	比率差动定值 Dif.P.R [Differential protection with ratio restraining value]	$0.5 * I_e$	$0.05 * I_e \sim 100 * I_e$	
	差流 2 次谐波制动系数 SHD [Differential Current Coefficient of secondary harmonics]	0.15	0.001~2	
	差流越限延时 Dif.I.OT [Differential current over limited delay]	10s	0~999	
CT 断线告警 [60] [CT supervision]	CT 断线闭锁比率差动 E.CTBr.B.Dif.R [Enable CT Break Block Differential protection]	1	0~1	退出; 投入 OFF; ON
	CT 断线告警投退 E.CTBr.A [Enable CT Break Alarm]	0	0~1	退出; 投入 OFF; ON
	CT 断线告警延时 CTBr.T [CT Break Alarm time]	0.5s	0~999	

	后备经突变量闭锁投退 E.Ba.B [Enable Emergency variable Block]	1	0~1	退出；投入 OFF； ON
	自启动判据投退 E.S.Sta. [Enable self-start criterion]	0	0~1	退出；投入 OFF； ON
启动时过流一段 3I>>>.S [50] [Instantaneous Overcurrent of Starting]	启动时过流一段投退 E.3I>>>.S [Enable.3I>>> of Starting]	0	0~1	退出；投入 OFF； ON
	启动一段定值 3I>>>.S [3I>>> value of starting]	10A	0.04~100	
	启动一段延时 3I>>>.Ts [3I>>>.start delay]	0s	0~999	
运行时过流一段 3I>>>.R [50] [Instantaneous Overcurrent of Running]	运行中过流一段投退 E.3I>>>.R [3I>>> value of Running]	0	0~1	退出；投入 OFF； ON
	运行一段定值 3I>>>.R [3I>>> value of running]	10A	0.04~100	
	运行一段延时 3I>>>.Tr [3I>>>.Running delay]	0s	0~999	
过流二段 3I>> [51] [Time-limited overcurrent]	过流二段投退 E.3I>> [Enable.3I>>]	0	0~1	退出；投入 OFF； ON
	过流二段定值 3I>> [3I>> value]	10A	0.04~100	
	过流二段延时 3I>>.T [3I>> delay]	0.1s	0~999	
反时限过流 I>Inv.	反时限过流投退 E.I>.Inv [Enable I> Inverse]	0	0~1	退出；投入 OFF； ON

[51] [Inverse time overcurrent (IDMT)]	反时限启动电流 I>.Inv [Inverse current]	1A	0.04~100	
	反时限时间系数 I>.Inv.K [Inverse time coefficient]	0.1s	0~999	
	反时限曲线类型 I>.Inv.X [Inverse curves]	0	0~2	一般；非常；极端 NI；VI；EI
I0 过流一段 I0>>> [50N] [Instantaneous ground fault overcurrent]	I0 过流一段投退 E.I0>>> [Enable I0>>>]	0	0~1	退出；投入 OFF；ON
	I0 过流一段定值 I0>>> [I0>>> value]	10A	0.04~100	
	I0 过流一段延时 I0>>>T [I0>>> delay]	0.1s	0~999	
I0 过流二段 I0>> [50N] [Time limited ground fault overcurrent]	I0 过流二段投退 E. I0>> [Enable I0>>]	0	0~1	退出；投入 OFF；ON
	I0 过流二段定值 I0>> [I0>> value]	2A	0.04~100	
	I0 过流二段延时 I0>>T [I0>> delay]	0.5s	0~999	
I0 反时限过流 I0.Inv [51N] [Inverse time ground fault]	I0 反时限投退 E. I0.Inv [Enable I0.Inv]	0	0~1	退出；投入 OFF；ON
	I0 反时限启动值 I0.Inv [I0.Inv starting value]	1A	0.04~100	
	I0 反时限系数 I0.Inv.K [I0.Inv time coefficient]	0.1s	0~999	
	I0 反时限曲线 I0.Inv.X [I0.Inv curves type]	0	0~2	一般；非常；极端 NI；VI；EI
负序过流一段 I2>>> [46] [Negative sequence instantaneous	负序一段投退 E. I2>>> [Enable I2>>>]	0	0~1	退出；投入 OFF；ON
	负序一段定值 I2>>>	10A	0.04~100	

overcurrent]	[I2>>> value]			
	负序一段延时 I2>>>.T [I2>>> delay]	0.1s	0~999	
负序过流二段 I2>> [46] [Negative sequence time-limited overcurrent]	负序二段投退 E. I2>> [Enable I2>>]	0	0~1	退出; 投入 OFF; ON
	负序二段定值 I2>> [I2>> value]	2A	0.04~100	
	负序二段延时 I2>>.T [I2>> delay]	0.5s	0~999	
负序反时限过流 I2.Inv.Tr [46] [Negative sequence inverse overcurrent(IDMT)]	负序反时限投退 E. I2>Inv [Enable I2>Inverse]	0	0~1	退出; 投入 OFF; ON
	负序反时限电流 I2>Inv [I2>Inverse value]	1A	0.04~100	
	负序反时限系数 I2>Inv.K [I2>Inverse. time coefficient]	0.1s	0~999	
	负序反时限曲线 I2>Inv.X [I2>Inverse curves]	0	0~2	一般; 非常; 极端 NI; VI; EI
过负荷保护 [49] Overload	过负荷保护投退 E.I>Lo [Enable Overload]	0	0~2	退出; 告警; 跳闸 OFF;Alarm;Trip
	过负荷保护定值 I>Lo [Overload value]	10A	0.04~100	
	过负荷保护延时 I>Lo.T [Overload delay]	5s	0~999	
堵转保护 [51LR] Locked rotor	堵转保护投退 E.Stall [Enable locked rotor]	0	0~1	退出; 投入 OFF; ON
	堵转电流定值 Stall.I	10A	0.04~100	

	[Locked rotor Current value]			
	堵转保护延时 Stall.T [Locked rotor delay]	1s	0~999	
过热保护 [49M] Thermal overload	过热时间常数 τ HeatPro.K [Thermal overload coefficient]	60s	0~999	
	过热保护告警投退 E.OverHeat.A [Enable Thermal overload Alarm]	0	0~1	退出；投入 OFF；ON
	过热保护告警定值 OverHeat.A [Thermal overload Alarm value]	70%	0~200	
	过热保护跳闸投退 E.OverHeat.T [Enable Thermal overload Trip]	0	0~1	退出；投入 OFF；ON
	过热保护跳闸定值 OverHeat.T [Thermal overload Trip value]	100%	0~200	
重启过热闭锁 HeatRestart Block	重启过热闭锁投退 E.HeatRe [Enable HeatRestart Block]	0	0~1	退出；投入 OFF；ON
	重启过热闭锁定值 HeatRe [Heat Restart value]	80%	0~200	
长启动保护 StartOutTime [66] [Motor Start time supervision]	长启动保护投退 E.SoutT [Enable Start out time]	0	0~1	退出；投入 OFF；ON
	长启动保护定值 SoutT [Startout time delay]	1.125	0~200	
电流不平衡	电流不平衡投退	0	0~2	退出；告警；跳闸

Unb.I [60] [Unbalance Current Protection]	E.Unb.I [Enable Unbalance Current]			OFF; Alarm; Trip
	电流不平衡定值 Unb.I [Unbalance Current value]	15%	0~200	
	电流不平衡延时 Unb.I.T [Unbalance Current delay]	5s	0~999	
不平衡电压保护 Unb.V [60] [Unbalance Voltage Protection]	不平衡电压投退 E.Unb.V [Enable Unbalance voltage]	0	0~2	退出; 告警; 跳闸 OFF; Alarm; Trip
	不平衡电压定值 Unb.V [Unbalance voltage value]	15%	0~200	
	不平衡电压延时 Unb.V.T [Unbalance Voltage delay]	5s	0~999	
相序保护 Incorrect Phase Protection	相序保护投退 E.Ph.Se. [Enable Staggered Phase]	0	0~2	退出; 告警; 跳闸 OFF; Alarm; Trip
	相序保护延时 Ph.Se.T [Staggered Phase delay]	0.1s	0~999	
	负序电压比例 U2 Ratio [Negative voltage Ratio]	50%	0~200	
	正序电压比例 U1 Ratio [Positive voltage Ratio]	30%	0~200	
	相序保护告警电压上限 LiV.HSet [Line voltage high setting]	120V	0~200	
	相序保护告警电压下限	70V	0~200	

	LiV.LSet [Line voltage low setting]			
电压断相保护 Voltage Phase Break Protection	电压断相投退 E.Ph.Br [Enable Voltage Phase Break]	0	0~1	退出；投入 OFF；ON
	电压断相延时 Ph.Br.T [Voltage Phase Break delay]	0.5s	0~200	
	断相最大电压定值 Ph.BrUmax [Maximum Voltage of Phase Break]	50V	0~200	
	断相最小电压定值 Ph.BrUmin [Minimum Voltage of Phase Break]	30V	0~200	
	断相电压差值 Ph.BrU.Dif [Phase Break differential Voltage]	120V	0~200	
过电压保护 OVP [59] [Overvoltage Protection]	过电压保护投退 E.OVP [Enable Overvoltage]	0	0~2	退出；告警；跳闸 OFF； Alarm;Trip
	过电压保护定值 U.OVP [Overvoltage value]	40V	0.04~200	
	过电压保护延时 OVP.T [Overvoltage delay]	5s	0~999	
零序过压保护 U0.OVP [59N] [Residual over voltage]	零序过压投退 E.U0.OVP [Enable Residual over voltage protection]	0	0~2	退出；告警；跳闸 OFF； Alarm;Trip
	零序过压定值 U0.OVP [Residual over voltage	40V	0.04~200	

	value]			
	零序过压延时 U0.OVP.T [Residual over voltage protection delay]	5s	0~100000	
低电压保护 LVP [27] [Undervoltage Protection]	低电压保护投退 E.LVP [Enable Undervoltage]	0	0~2	退出; 告警; 跳闸 OFF; Alarm; Trip
	低电压保护定值 LVP [Undervoltage value]	50V	1~200	
	低电压保护延时 LVP.T [Undervoltage delay]	5s	0~999	
非电量 1 跳闸 Non-electricity1 Trip	非电量 1 跳闸投退 E.Non-el1.T [Enable Non-electricity1 Trip]	0	0~1	退出; 投入 OFF; ON
	非电量 1 跳闸延时 Non-el1.T.T [Enable Non-electricity1 Trip delay]	0.1s	0~999	
非电量 1 告警 Non-electricity1 Alarm	非电量 1 告警投退 E.Non-el1.A [Enable Non-electricity1 Alarm]	0	0~1	退出; 投入 OFF; ON
	非电量 1 告警延时 Non-el1.A.T [Enable Non-electricity1 Alarm delay]	5s	0~999	
非电量 2 跳闸 Non-electricity2 Trip	非电量 2 跳闸投退 E.Non-el2.T [Enable Non-electricity2 Trip]	0	0~1	退出; 投入 OFF; ON
	非电量 2 跳闸延时 Non-el2.T.T	0.1s	0~999	

	[Enable Non-electricity2 Trip delay]			
非电量 2 告警 Non-electricity2 Alarm	非电量 2 告警投退 E.Non-el2.A [Enable Non-electricity2 Alarm]	0	0~1	退出；投入 OFF； ON
	非电量 2 告警延时 Non-el2.A.T [Enable Non-electricity2 Alarm delay]	5s	0~999	
FC 配合的过流闭锁 FC Block	FC 闭锁投退 E. FCBlock [Enable FC Block]	0	0~1	退出；投入 OFF； ON [When the fault current is greater than FCBlock.I, the relay's DO will be blocked,in order to ensure that the fuse is first blown.]
	FC 闭锁电流定值 FCBlock.I [FC Block current value]	70A	0.04~120	
	FC 闭锁延时 FCBlock.T [FC Block delay]	0s	0~60	
PT 断线 PT supervision[60]	PT 断线告警投退 E.PtBr.A [Enable PT Break alarm]	0	0~1	退出；投入 OFF； ON
	PT 断线负序电压 U2.Pt [Negative sequence voltage]	30V	0~200	
	PT 断线告警延时 PtBr.T [PT Break delay]	0.5s	0~999	
控故障告警 Trip and close circuit supervision	控故障告警投退 E.CB.A [Enable Trip and close circuit supervision alarm]	0	0~1	退出；投入 OFF； ON
	控故障告警延时 CB.A.T	0.3s	0~999	

	[Trip and close circuit supervision alarm delay]			
	事故总信号延时 Acci.S.T [Accident Signal delay]	0.3s	0~999	
	断路器位置采集 CB Po.Ac [Circuit Breaker position Collection]	1	0~1	辅助触点; 分合位监视 Auxiliary.C;CB M. [Auxiliary contact;Circuit Breaker Monitor]
	断路器动作时间 Cir.Br.T [Circuit Breaker trip and close time]	0.3s	0~999	
	过量返回系数 Excess R.C [Excess Return Coefficient]	0.95	0.001~1	
	欠量返回系数 Under R.C [Under Return Coefficient]	1.05	1~2	
检修状态闭锁 Over Haul-lockout	检修状态闭锁通讯投退 E. M.BC [Enable Overhaul-lockout communication]	0	0~1	退出; 投入 OFF; ON
	检修状态闭锁出口投退 E. M.BE [Enable Overhaul-lockout DO]	0	0~1	退出; 投入 OFF; ON
	跳闸展宽 Tripping pulse	0.3s	0~1	

AM5SE-D2 定值表				
AM5SE-D2 Setting				
保护名称 Protection Name	定值名称 Value Name	默认值 Default	范围 Range	备注 Remark
	变压器额定容量 RL [Rated Load]	120MV A	1~3000.00	MVA

	I 侧 PT 变比 I_PT	350	0.1~10000	
	I 侧接线方式 I_Mode	0	0~1	Y; D
	II 侧接线方式 II_Mode	11	1~12	
	I 侧接地变在引线上 I_Lead	0	0~1	否; 是 No;Yes
	II 侧接地变在引线上 II_Lead	0	0~1	否; 是 No;Yes
	I 侧额定电压 I_Ue	35kV	0~1000	kV
	II 侧额定电压 II_Ue	10kV	0~1000	kV
	I 侧 CT 一次值 I_CT Ie1 [I-CT Primary]	600A	0~99999	
	I 侧 CT 二次值 I_CT Ie [I-CT Secondary]	5A	0~10000	
	II 侧 CT 一次值 II_CT Ie1 [II-CT Primary]	1000A	0~99999	
	II 侧 CT 二次值 II_CT Ie [II-CT Secondary]	5A	0~10000	
	电压接线方式 PT Mode [Voltage measurement mode]	0	0~1	3PT; 2PT
	电流接线方式 CT Mode [Current measurement mode]	0	0~1	3CT; 2CT
	零序电压来源 U0 Source	1	0~1	外接; 自产 U0;self-produced
	低压阈值	15V	0~200	复合电压判据

	U. Less [Under Voltage threshold]			Composite Voltage Criterion
	低电压定值 U.Under [Under Voltage value]	70V	0~200	
	复合电压负序定值 U2 [Negative voltage value]	35V	0~200	
差动速断 [87T] Instantaneous Differential protection	差动速断投退 E.Ins.Dif [Enable Instantaneous Differential]	0	0~1	退出; 投入 OFF; ON
	差动速断定值 Ins.Dif [Instantaneous Differential value]	$8 * I_e$	$0.05 * I_e \sim 100 * I_e$	$I_e = I_{e_h}$
比率差动 [87T] Differential protection with ratio restraining	比率差动投退 E.Dif.P.R [Enable Differential protection with ratio restraining]	0	0~1	退出; 投入 OFF; ON
	比率差断定值 Dif.P.R [Differential protection with ratio restraining value]	$0.5 * I_e$	$0.05 * I_e \sim 100 * I_e$	$I_e = I_{e_h}$
	差流越限延时 Dif.I.OT [Differential current over limit delay]	10s	0~999	
	差动保护长期启动延时 Dif.S.T [Differential protection Start delay]	20s	0~999	
	CT 断线闭锁比率差动 E.CTBr.B.Dif.R	1	0~1	退出; 投入 OFF; ON

	[Enable CT Break Block Differential protection]			
CT 断线告警 CT supervision[60]	CT 断线告警投退 E.CTBr.A [Enable CT Break Alarm]	0	0~1	退出; 投入 OFF; ON
	CT 断线告警延时 CTBr.T [CT Break Alarm time]	0.5s	0~999	
FC 闭锁 FC Block	FC 闭锁投退 E. FCBlock [Enable FC Block]	0	0~1	退出; 投入 OFF;ON [When the fault current is greater than FCBlock.I, the relay's DO will be blocked, in order to ensure that the fuse is first blown.]
	FC 闭锁电流定值 FCBlock.I [FC Block current value]	70A	0~100	
	FC 闭锁延时 FCBlock.T [FC Block delay]	0s	0~999	
控故障告警 Trip and close circuit supervision	控故障告警投退 E.CB.A [Enable Trip and close circuit supervision alarm]	0	0~1	退出; 投入 OFF; ON
	控故障告警延时 CB.A.T [Trip and close circuit supervision alarm delay]	0.3s	0~999	
	事故总信号延时 Acci.S.T [Accident Signal delay]	0.3s	0~999	
	断路器位置采集 CB Po.Ac [Circuit Breaker position Collection]	1	0~1	辅助触点; 分合位监视 Auxiliary.C;CB M. [Auxiliary contact;Circuit Breaker Monitor]
	断路器动作时间 Cir.Br.T	0.3s	0~999	

	[Circuit Breaker trip and close time]			
检修状态闭锁 Over Haul-lockout	检修状态闭锁通讯投退 E. M.BC [Enable Overhaul-lockout communication]	0	0~1	退出；投入 OFF；ON
	检修状态闭锁出口投退 E. M.BE [Enable Overhaul-lockout DO]	0	0~1	退出；投入 OFF；ON
	跳闸展宽 Tripping pulse	0.3s	0~1	

AM5SE-TB 定值表 AM5SE-TB Setting				
保护名称 Protection Name	定值名称 Value Name	默认值 Default	范围 Range	备注 Remark
	PT 变比 PT	100	0.1~10000	
	CT 变比 CT	50	0.1~10000	
	一次电压显示 U Unit [Primary voltage display]	0	0~1	kV;V
	电压接线方式 PT Mode [Voltage measurement mode]	0	0~1	3PT; 2PT
	电流接线方式 CT Mode [Current measurement mode]	0	0~1	3CT; 2CT
	零序电压来源 U0 Source	1	0~1	外接；自产 U0;3U0 U0;self-produced
	低压阈值 U.Less [Under Voltage threshold]	15V	0~200	复合电压判据 Composite Voltage Criterion
	低电压定值	70V	0~200	

	U.Under [Under Voltage value]			
	复合电压负序定值 U2 [Negative voltage value]	35V	0~200	
启动风冷 Starting air-cooled water chiller	启动风冷投退 E.S.Air.C [Enable Start Air-Cooled]	0	0~1	退出；投入 OFF； ON
	启动风冷定值 S.Air.C [Start Air-Cooled value]	2A	0.04~120	
	启动风冷延时 S.Air.C.T [Start Air-Cooled delay]	2s	0~999	
闭锁调压 On-load tap charge lock-out	闭锁调压投退 E.Vol.Re.B [Enable On-load tap charge lock-out]	0	0~1	退出；投入 OFF； ON
	闭锁调压定值 Vol.Re.B [On-load tap charge lock-out value]	3A	0.04~120	
	闭锁调压延时 Vol.Re.B.T [On-load tap charge lock-out delay]	2s	0~999	
过流一段 3I>>> [50] [Instantaneous overcurrent]	过流一段投退 E.3I>>> [Enable.3I>>>]	0	0~1	退出；投入 OFF； ON
	过流一段定值 3I>>> [3I>>> value]	10A	0.04~120	
	过流一段复压闭锁 E.3I>>>.U2 [Enable.3I>>> .Composite	0	0~1	退出；投入 OFF； ON [If enable 3I>>>.U2, composite

	Voltage]			voltage conditions should be considered for overcurrent protection. When the smallest of the three line voltages is less than U.Under and greater than U.Less or the negative voltage greater than U2 the overcurrent protection DO is prepare work.]
	过流一段带方向 E.3I>>>.D[67] [Enable.3I>>> .direction]	0	0~2	不带方向；指向线路；指向母线 OFF； Line； Bus
	过流一段延时 3I>>>.T [3I>>> delay]	0s	0~999	
过流二段 3I>> [51] [Time-limited overcurrent]	过流二段投退 E.3I>> [Enable.3I>>]	0	0~1	退出；投入 OFF； ON
	过流二段定值 3I>> [3I>> value]	10A	0.04~120	
	过流二段复压闭锁 E.3I>>.U2 [Enable.3I>> .Composite Voltage]	0	0~1	退出；投入 OFF； ON [If enable 3I>>.U2, composite voltage conditions should be considered for overcurrent protection. When the smallest of the three line voltages is less than U.Under and greater than U.Less or the negative voltage greater than U2 the overcurrent protection DO is prepare work.]
	过流二段带方向 E.3I>>.D[67] [Enable.3I>> .direction]	0	0~2	不带方向；指向线路；指向母线 OFF； Line； Bus
	过流二段延时	0.1s	0~999	

	3I>>.T [3I>> delay]			
过流三段 3I> [51] [Definite time overcurrent]	过流三段投退 E.3I> [Enable.3I>]	0	0~1	退出; 投入 OFF; ON
	过流三段定值 3I> [3I> value]	10A	0.04~120	
	过流三段复压闭锁 E.3I>.U2 [Enable.3I> .Composite Voltage]	0	0~1	退出; 投入 OFF; ON [If enable 3I>.U2, composite voltage conditions should be considered for overcurrent protection. When the smallest of the three line voltages is less than U.Under and greater than U.Less or the negative voltage greater than U2 the overcurrent protection DO is prepare work.]
	过流三段带方向 E.3I>.D[67] [Enable.3I>.direction]	0	0~2	不带方向; 指向线路; 指向母线 OFF; Line; Bus
	过流三段延时 3I>.T [3I> delay]	0.5s	0~999	
	反时限过流投退 E.I>.Inv [Enable I> Inverse]	0	0~1	退出; 投入 OFF; ON
反时限过流 I>Inv. [51] [Inverse time overcurrent (IDMT)]	反时限经复压闭锁 E.I>.Inv.U [Enable.I>Inv. composite voltage]	0	0~1	退出; 投入 OFF; ON [If enable I>.Inv, composite voltage conditions should be considered for overcurrent protection. When the smallest of the three line voltages is less than

				U.Under and greater than U.Less or the negative voltage greater than U2 the overcurrent protection DO is prepare work.]
	反时限启动电流 I>.Inv [Inverse current]	1A	0.04~120	
	反时限时间系数 I>.Inv.K [Inverse time coefficient]	0.1s	0~999	
	反时限曲线类型 I>.Inv.X [Inverse curves]	0	0~2	一般；非常；极端 NI；VI；EI
I0 过流一段 I0>>> [50N] [Instantaneous ground fault overcurrent]	I0 过流一段投退 E.I0>>> [Enable I0>>>]	0	0~1	退出；投入 OFF；ON
	I0 过流一段定值 I0>>> [I0>>> value]	10A	0.04~120	
	I0 过流一段延时 I0>>>T [I0>>> delay]	0.1s	0~999	
I0 过流二段 I0>> [51N] [Time limited ground fault overcurrent]	I0 过流二段投退 I0>> [Enable I0>>]	0	0~2	退出；告警；跳闸 OFF；Alarm；Trip
	I0 过流二段定值 I0>> [I0>> value]	2A	0.04~120	
	I01 过流二段延时 I0>>T [I0>> delay]	0.5s	0~999	
I0 反时限过流 I0.Inv [51N] [Inverse time ground fault]	I0 反时限投退 E.I0.Inv [Enable I0.Inverse]	0	0~1	退出；投入 OFF；ON
	I0 反时限启动值 I0.Inv [I0.Inv starting value]	1A	0.04~120	
	I0 反时限系数 I0.Inv.K [I0 Inverse coefficient]	0.1s	0~999	
	I0 反时限曲线 I0.Inv.X	0	0~2	一般；非常；极端

	[I0 Inverse curves]			NI; VI; EI
过负荷告警 I>Lo.A [49F] [Overload Alarm]	过负荷告警投退 E.I>Lo.A [Enable Overload Alarm]	0	0~1	退出; 投入 OFF; ON
	过负荷告警定值 I>Lo.A [Overload Alarm value]	10A	0.04~120	
	过负荷告警延时 I>Lo.A.T [Overload Alarm delay]	5s	0~999	
过负荷跳闸 I>Lo.T [49F] [Overload Trip]	过负荷跳闸投退 E.I>Lo.T [Enable Overload Trip]	0	0~1	退出; 投入 OFF; ON
	过负荷跳闸定值 I>Lo.T [Overload Trip value]	10A	0.04~120	
	过负荷跳闸延时 I>Lo.T.T [Overload Trip delay]	1s	0~999	
轻瓦斯告警 Light Gas Alarm	轻瓦斯告警投退 E.LGas.A [Enable Light Gas Alarm]	0	0~1	退出; 投入 OFF; ON
	轻瓦斯告警延时 LGas.T [Light Gas Alarm delay]	5s	0~999	
重瓦斯跳闸 Heavy Gas trip	重瓦斯跳闸投退 E.SGas.T [Enable Heavy Gas Trip]	0	0~1	退出; 投入 OFF; ON
	重瓦斯跳闸延时 SGas.T [Heavy Gas delay]	0s	0~999	
压力释放 Pressure Release	压力释放投退 E. Pre.Re [Enable Pressure Release]	0	0~1	退出; 投入 OFF; ON
	压力释放延时	5s	0~999	

	Pre.Re.T [Pressure Release delay]			
高温告警 Over temperature Alarm	高温告警投退 E.OTem.A [Enable Over temperature Alarm]	0	0~1	退出；投入 OFF； ON
	高温告警延时 OTem.T [Over temperature Alarm delay]	5s	0~999	
超温跳闸 High temperature Trip	超温跳闸投退 E.HTem.T [Enable High temperature Trip]	0	0~1	退出；投入 OFF； ON
	超温跳闸延时 HTem.T [High temperature Trip delay]	0s	0~999	
开关气体跳闸 Switch Gas Trip	开关气体跳闸投退 E.S.G.T [Enable Switch Gas Trip]	0	0~1	退出；投入 OFF； ON
	开关气体跳闸延时 S.G.T.T [Switch Gas Trip delay]	5s	0~999	
开关气体告警 Switch Gas Alarm	开关气体告警投退 E.S.G.A [Enable Switch Gas Alarm]	0	0~1	退出；投入 OFF； ON
	开关气体告警延时 S.G.A.T [Switch Gas Alarm delay]	5s	0~999	
本体油位高 Body High Oil	本体油位高告警投退 E.B.H [Enable Body High Oil]	0	0~2	退出；告警；跳闸 OFF； Alarm； Trip
	本体油位高延时 B.H.T [Body High Oil delay]	5s	0~999	

间隙零序 过流一段 [50N] Clearance Instantaneous earth fault protection	间隙零序过流一段投退 E.C.I0>>> [Enable Clearance I0>>>]	0	0~1	退出；投入 OFF； ON
	间隙零序过流一段定值 C.I0>>> [Clearance I0>>> value]	10A	0.04~120	
	间隙零序过流一段延时 C.I0>>>.T [Clearance I0>>> delay]	0.1s	0~999	
间隙零序 过流二段 [50N] Clearance Time-limited earth fault protection	间隙零序过流二段投退 E.C.I0>> [Enable Clearance I0>>]	0	0~2	退出；告警；跳闸 OFF； Alarm； Trip
	间隙零序过流二段定值 C.I0>> [Clearance I0>> value]	10A	0.04~120	
	间隙零序过流二段延时 C.I0>>.T [Clearance I0>>> delay]	0.1s	0~999	
自产零序 过流一段 [50N] Self-produced Instantaneous earth fault protection	自产零序过流一段投退 E.3I0>>> [Enable 3I0>>>]	0	0~1	退出；投入 OFF； ON
	自产零序一段带方向 E.3I0>>>D[67N] [Enable 3I0>>>.direction]	0	0~2	不带方向；指向线路；指向母线 OFF； Line； Bus
	自产零序过流一段定值 3I0>>> [3I0>>> value]	10A	0.04~120	
	自产零序电压定值 1 3U01	5V	0~200	
	自产零序过流一段延时 3I0>>>.T [3I0>>> delay]	0.1s	0~999	
自产零序 过流二段 [50N]	自产零序过流二段投退 E.3I0>> [Enable 3I0>>]	0	0~2	退出；告警；跳闸 OFF； Alarm； Trip

Self-produced Time-limited earth fault protection	自产零序二段带方向 E.3I0>>D[67N] [Enable 3I0>>.direction]	0	0~2	不带方向；指向线路；指向母线 OFF； Line； Bus
	自产零序过流二段定值 3I0>> [3I0>> value]	10A	0.04~120	
	自产零序电压定值 2 3U02	5V	0~200	
	自产零序过流二段延时 3I0>>.T [3I0>> delay]	0.1s	0~999	
零序过压跳闸 U0.OVP.T [59N] [Residual over voltage Trip]	零序过压一段跳闸投退 E.U0.OVP [Enable Residual over voltage trip]	0	0~1	退出；投入 OFF； ON
	零序过压一段跳闸定值 U0.OVP [Residual over voltage trip value]	5V	0~200	
	零序过压一段跳闸延时 U0.OVP.T [Residual over voltage trip delay]	5s	0~999	
零序过压告警 U0.OVP.A [59N] [Residual Over Voltage Alarm]	零序过压二段告警投退 E.U0.OVP.A [Enable U0.OVP alarm]	0	0~1	退出；投入 OFF； ON
	零序过压二段告警定值 U0.OVP.A [Residual over voltage alarm value]	5V	0~200	
	零序过压二段告警延时 U0.OVP.A.T [Residual over voltage alarm delay]	5s	0~999	
PT 断线告警	PT 断线告警投退	0	0~1	退出；投入

PT supervision[60]	E.PtBr.A [Enable PT break alarm]			OFF; ON
	PT 断线负序电压 U2.Pt [PT break negative sequence voltage]	35V	0~200	
	无压定值 U.None [No-Voltage]	10V	0~200	
	无流定值 I.None [No-Current]	0.2A	0.04~100	
	PT 断线告警延时 PtBr.T [PT break alarm delay]	5s	0~999	
FC 闭锁 FC Block	FC 闭锁后备投退 E.FCBlock [Enable FC Block]	0	0~1	退出; 投入 OFF; ON
	FC 闭锁后备定值 FCB.I [FC Block current value]	10A	0~120	
	FC 闭锁后备延时 FCB.T [FC Block delay]	0s	0~999	
控故障告警 Trip and close circuit supervision	控故障告警投退 E.CB.A [Enable Trip and close circuit supervision alarm]	0	0~1	退出; 投入 OFF; ON
	控故障告警延时 CB.A.T [Trip and close circuit supervision alarm delay]	0.3s	0~999	
	事故总信号延时 Acci.S.T [Accident Signal delay]	0.3s	0~999	
	EMC 闭锁投退 E.EMC.B [Enable EMC Block]	1	0~1	退出; 投入 OFF; ON

	断路器位置采集 CB Po.Ac [Circuit Breaker position Collection]	1	0~1	辅助触点；分合位监视 Auxiliary.C;CB M. [Auxiliary contact;Circuit Breaker Monitor]
	断路器动作时间 Cir.Br.T [Circuit Breaker trip and close time]	0.3s	0~999	
BCD 码 开入配置 BCD DI Configure	开入配置组 1 (BCD 码个位) DI.Conf.1 [DI configuration 1]	0	0~1	退出；投入 OFF；ON
	开入配置组 2 (BCD 码十位) DI.Conf.2 [DI configuration 2]	0	0~1	退出；投入 OFF；ON
	开入配置组 3 (BCD 码百位) DI.Conf.3 [DI configuration 3]	0	0~1	退出；投入 OFF；ON
	遥控脉宽 Remote.P.W [Remote Pulse Width]	2000ms	0~999999999	
	遥调脉宽 Remote.M.P.W [Remote adjustment Pulse Width]	3000ms	0~999999999	
本体油位低 Body Low Oil	本体油位低跳闸投退 E.B.L.T [Enable Body Low Oil]	0	0~1	退出；告警；跳闸 OFF；Alarm；Trip
	本体油位低跳闸延时 B.L.T.T [Body Low Oil delay]	5s	0~999	
开关油位高 Switch High Oil	开关油位高跳闸投退 E.S.H.T [Enable Switch High Oil]	0	0~1	退出；告警；跳闸 OFF；Alarm；Trip
	开关油位高跳闸延时 S.H.T.T	5s	0~999	

	[Switch High Oil delay]			
开关油位低 Switch Low Oil	开关油位低跳闸投退 E.S.L.T [Enable Switch Low Oil]	0	0~1	退出; 告警; 跳闸 OFF; Alarm; Trip
	开关油位低跳闸延时 S.L.T.T [Switch Low Oil delay]	5s	0~999	
检修状态闭锁 Over Haul-lockout	检修状态闭锁通讯投退 E. M.BC [Enable Overhaul-lockout communication]	0	0~1	退出; 投入 OFF; ON
	检修状态闭锁出口投退 E. M.BE [Enable Overhaul-lockout DO]	0	0~1	退出; 投入 OFF; ON
	跳闸展宽 Tripping pulse	0.3s	0~1	
	I0 参与 2CT 计算 I0 P 2CT [I0 participate in 2CT calculation]	0	0~1	保护 CT 不同变比; 保护 CT 同变比 CT D.R; CT S.R [protective CT is different from zero sequence CT]; [protective CT is same as zero sequence CT] [When there are 2CT, wheather zero sequence current is involved in the calculation of Ib.]

AM5SE-UB 定值表				
AM5SE-UB Setting				
保护名称 Protection Name	定值名称 Value Name	默认值 Default	范围 Range	备注 Remark
	柜号 Cabinet No.	0	0~1	I 母 PT 柜; II 母 PT 柜 I_PT; II_PT
	PT 变比 PT	100	0.1~10000	
	电压接线方式	0	0~1	3PT; 2PT

	PT Mode [Voltage measurement mode]			
	零序电压来源 U0 Source	1	0~1	外接; 自产 U0; self-produced
	低压阈值 U. Less [Under Voltage threshold]	15V	0~200	复合电压判据 Composite Voltage Criterion
	低电压定值 U. Under [Under Voltage value]	70V	0~200	
	复合电压负序定值 U2 [Negative voltage value]	35V	0~200	
	I_PT 投入延时 I_PT.T [Put I_PT.delay]	5s	0~999	
	II_PT 投入延时 II_PT.T [Put II_PT.delay]	5s	0~999	
	判母联工作位 J.B.W.T [Enable Judge Bus Work Position]	0	0~1	退出; 投入 OFF; ON
	PT 自动并列投退 E.PTAu.P [Enable PT Auto Parallel]	0	0~1	退出; 投入 OFF; ON
	PT 自动并列延时 PTAu.P.T [PT Auto Parallel delay]	0s	0~999	
	PT 遥控并列投退 E.PTRe.P [Enable PT Remote Parallel]	0	0~1	退出; 投入 OFF; ON
	遥控并列返回延 T Re.PRT [Remote Put Reset delay]	5s	0~999	

	遥控解列返回 T Re.S.RT [Remote Split Reset delay]	10s	0~999	
I 母低电压告警 LVP.A [27] [I_Bus Undervoltage Alarm]	1#低压告警投退 E.1#LVPA [Enable 1#Undervoltage Alarm]	0	0~1	退出；投入 OFF；ON
	1#低压告警定值 1#LVPA [1#Undervoltage Alarm value]	70V	0~200	
	1#低压告警延时 1#LVPA.T [1#Undervoltage Alarm delay]	5s	0~999	
I 母过电压告警 [59] [I_Bus Overvoltage Protection Alarm]	1#过压告警投退 E.1#OVP.A [Enable 1#Overvoltage Alarm]	0	0~1	退出；投入 OFF；ON
	1#过压告警定值 1#OVP.A [1#Overvoltage Alarm value]	70V	0~200	
	1#过压告警延时 1#OVP.A.T [1#Overvoltage Alarm delay]	5s	0~999	
I 母 PT 断线告警 [I_Bus PT supervision]	1#PT 断线投退 E.1#PtBr.A [Enable 1#PT Break Alarm]	0	0~1	退出；投入 OFF；ON
	1#PT 断线电压值 1#PtBr.U [1#PT Break Alarm value]	16V	0~200	
	1#PT 断线 U2 定值 1#PT Break negative voltage value	35V	0~200	
	1#PT 断线延时	5s	0~999	

	1#PtBr.T [1#PT Break delay]			
I 母零序过压告警 [59N] [I_BUS Residual Overvoltage Alarm]	1#U0 过压投退 E.1#U0.OVP [Enable #1Residual Overvoltage]	0	0~1	退出; 投入 OFF; ON
	1#U0 过压定值 1#U0.OVP [#1Residual Overvoltage value]	5V	0~200	
	1#U0 过压延时 1#U0.OVP.T [#1Residual Overvoltage delay]	5s	0~999	
II 母低电压告警 LVP.A [27] [II_Bus Undervoltage Alarm]	2#低压告警投退 E.2#LVPA [Enable 2#Undervoltage Alarm]	0	0~1	退出; 投入 OFF; ON
	2#低压告警定值 2#LVP.A [2#Undervoltage Alarm value]	70V	0~200	
	2#低压告警延时 2#LVP.A.T [2#Undervoltage Alarm delay]	5s	0~999	
II 母过电压告警 [59] [II_Bus Overvoltage Alarm]	2#过压告警投退 E.2#OVPA [Enable 2#Overvoltage Alarm]	0	0~1	退出; 投入 OFF; ON
	2#过压告警定值 2#OVPA [2#Overvoltage value]	70V	0~200	
	2#过压告警延时 2#OVPA.T	5s	0~999	

	[2#Overvoltage Alarm delay]			
II 母 PT 断线告警 [II_Bus PT supervision]	2#PT 断线投退 E.2#PtBr.A [Enable 2#PT Break Alarm]	0	0~1	退出; 投入 OFF; ON
	2#PT 断线电压值 2#PtBr.U [2#PT Break Alarm value]	16V	0~200	
	2#PT 断线 U2 定值 2#PT Break negative voltage value	35V	0~200	
	2#PT 断线延时 2#PtBr.T [2#PT Break delay]	5s	0~999	
II 母零序过压告警 [59N] [II_U0 Overvoltage Protection Alarm]	2#U0 过压投退 E.2#U0.OVP [Enable #2 Residual Overvoltage]	0	0~1	退出; 投入 OFF; ON
	2#U0 过压定值 2#U0.OVP [#2 Residual Overvoltage value]	5V	0~200	
	2#U0 过压延时 2#U0.OVP.T [#2 Residual Overvoltage delay]	5s	0~999	
	继电器脉冲宽度 R.Pul.W [Relay Pulse width]	0.3s	0.1~999	
I 母消谐功能 I_Resonance elimination	1#消谐功能投退 E.1#RE [Enable 1#Resonance elimination]	0	0~1	退出; 投入 OFF; ON
	1#零序测频阈值 1#U0.Fr. [1# Residual voltage]	25V	5~70	

	Frequency value]			
	1#启动电压定值 1#R.S.U [1#Resonance Start voltage]	30V	0~200	
	1#谐振动作延时 1#R.A.T [1#Resonance Action delay]	0.1s	0~999	
	1#基频电压定值 1#F.Fr.U [1#Fundamental Frequency voltage]	125V	0~200	
	1#三分频电压定值 1#1/3FrU [1# 1/3 Frequency voltage]	30V	0~200	
	1#二分频电压定值 1#1/2FrU [1# 1/2 Frequency voltage]	30V	0~200	
	1#三倍频电压定值 1#3Fr.U [1# 3 Frequency voltage]	30V	0~200	
	1#单相接地低定值 1#SG.U.L [1#Single-phase ground under voltage]	40V	0~200	
	1#单相接地高定值 1#SG.U.U [1#Single-phase ground high voltage]	120V	0~200	
II 母消谐功能 II_Resonance elimination	2#消谐功能投退 E.2#RE [Enable 2#Resonance elimination]	0	0~1	退出; 投入 OFF; ON
	2#零序测频阈值 2#U0.Fr. [2# Residual voltage]	25V	5~70	

	Frequency value]			
	2#启动电压定值 2#R.S.U [2#Resonance Start voltage]	30V	0~200	
	2#谐振动作延时 2#R.A.T [2#Resonance Action delay]	0.1s	0~999	
	2#基频电压定值 2#F.Fr.U [2#Fundamental Frequency voltage]	125V	0~200	
	2#三分频电压定值 2#1/3FrU [2# 1/3 Frequency voltage]	30V	0~200	
	2#二分频电压定值 2#1/2FrU [2# 1/2 Frequency voltage]	30V	0~200	
	2#三倍频电压定值 2#3Fr.U [2# 3 Frequency voltage]	30V	0~200	
	2#单相接地低定值 2#SG.U.L [2#Single-phase ground low voltage]	40V	0~200	
	2#单相接地高定值 2#SG.U.U [2#Single-phase ground high voltage]	120V	0~200	

AM5SE-D3 定值表				
AM5SE-D3 Setting				
保护名称	定值名称	默认值	范围	备注
Protection Name	Value Name	Default	Range	Remark
	变压器额定容量 RL	120MVA	1~3000.00	MVA

	[Rated Load]			
	I 侧 PT 变比 I_PT	100	0.1~10000	
	I 侧接线方式 I_Mode	0	0~1	Y; D
	II 侧接线方式 II_Mode	11	1~12	
	III 侧接线方式 III_Mode	11	1~12	
	I 侧接地变在引线上 I_Lead	0	0~1	否; 是 NO;Yes
	II 侧接地变在引线上 II_Lead	0	0~1	否; 是 NO;Yes
	III 侧接地变在引线上 III_Lead	0	0~1	否; 是 NO;Yes
	I 侧额定电压 I_Ue	110kV	0~1000	kV
	II 侧额定电压 II_Ue	35kV	0~1000	kV
	III 侧额定电压 III_Ue	10kV	0~1000	kV
	I 侧 CT 一次值 I_CT Ie1 [I-CT Primary]	600A	0~100000	
	I 侧 CT 二次值 I_CT Ie [I-CT Secondary]	5A	0~120	
	II 侧 CT 一次值 II_CT Ie1 [II-CT Primary]	1000A	0~100000	
	II 侧 CT 二次值 II_CT Ie [II-CT Secondary]	5A	0~120	
	III 侧 CT 一次值 III_CT Ie1	2000A	0~100000	

	[III-CT Primary]			
	III 侧 CT 二次值 III_CT Ie [III-CT Secondary]	5A	0~120	
	电压接线方式 PT mode [Voltage measurement mode]	0	0~1	3PT; 2PT
	电流接线方式 CT Mode [Current measurement mode]	0	0~1	3CT; 2CT
	零序电压来源 U0 Source	1	0~1	外接; 自产 U0;self-produced
	低压阈值 U. Less [Undervoltage threshold]	15V	0~200	复合电压判据 Composite Voltage Criterion
	低电压定值 U. Under [Undervoltage value]	70V	0~200	
	复合电压负序定值 U2 [Negative voltage value]	35V	0~200	
差动速断 [87T] Instantaneous Differential protection	差动速断投退 E.Ins.Dif [Enable Instantaneous Differential]	0	0~1	退出; 投入 OFF; ON
	差动速断定值 Ins.Dif [Instantaneous Differential value]	$8 * I_e$	$0.05 * I_e \sim 120 * I_e$	$I_e = I_{ch}$
比率差动 [87T] Differential protection with ratio restraining	比率差动投退 E.Dif.P.R [Enable Differential protection with ratio restraining]	0	0~1	退出; 投入 OFF; ON
	比率差断定值 Dif.P.R	$0.5 * I_e$	$0.05 * I_e \sim 120 * I_e$	$I_e = I_{ch}$

	[Differential protection with ratio restraining value]			
	差流越限延时 Dif.I.OT [Differential current over limit delay]	10s	0~100000	
	差动保护长期启动延时 Dif.S.T [[Differential protection Start delay]]	20s	0~100000	
	CT 断线闭锁比率差动 E.CTBr.B.Dif.R [Enable CT Break Block Differential protection]	1	0~1	退出；投入 OFF； ON
CT 断线告警 CT supervision[60]	CT 断线告警投退 E.CTBr.A [Enable CT Break Alarm]	0	0~1	退出；投入 OFF； ON
	CT 断线告警延时 CTBr.T [CT Break Alarm time]	0.5s	0~100000	
FC 闭锁 FC Block	FC 闭锁后备投退 E.FCBlock [Enable FC Block]	0	0~1	退出；投入 OFF； ON
	FC 闭锁后备定值 FCB.I [FC Block current value]	70A	0~120	
	FC 闭锁后备延时 FCB.T [FC Block delay]	0s	0~100000	
控故障告警 Trip and close circuit supervision	控故障告警投退 E.CB.A [Enable Trip and close circuit supervision alarm]	0	0~1	退出；投入 OFF； ON
	控故障告警延时 CB.A.T [Trip and close circuit supervision alarm delay]	0.3s	0~100000	

	事故总信号延时 Acci.S.T [Accident Signal delay]	0.3s	0~999	
	断路器位置采集 CB Po.Ac [Circuit Breaker position Collection]	1	0~1	辅助触点；分合位监视 Auxiliary.C;CB M. [Auxiliary contact;Circuit Breaker Monitor]
	断路器动作时间 Cir.Br.T [Circuit Breaker trip and close time]	0.3s	0~999	
	跳闸展宽 Tripping pulse	0.3s	0~1	

AM5SE-IS 定值表 AM5SE-IS Setting				
保护名称 Protection Name	定值名称 Value Name	默认值 Default	范围 Range	备注 Remark
	CT 变比 CT	10	0.1~9999	
	PT 变比 PT	100	0.1~9999	
	一次电压显示 U Unit [Primary voltage display]	0	0~1	kV;V
	母线电压接线方式 B.PT Mode [Bus voltage Mode]	0	0~1	3PT; 2PT
	进线电压接线方式 In.PT Mode [Incoming voltage Mode]	0	0~1	3PT; 2PT
	保护电流接线方式	0	0~1	3CT; 2CT

	P.CT Mode [Protective CT Mode]			
	测量电流接线方式 M.CT Mode [Measurment CT Mode]	0	0~1	3CT; 2CT
	分合位采集 CB On/Off A. [Circuit Breaker On/Off Acquisition]	0	0~2	分合双点; 合位单点; 分位单点 CCB On/Off; CCB On; CCB Off [Circuit Breaker On/Off; Circuit Breaker On; Circuit Breaker Off]
	低压阈值 U.Less [Under Voltage threshold]	15V	0~200	
	低电压定值 U.Under [Under Voltage value]	70V	0~500	
过流一段 3I>>> [50] [Instantaneous overcurrent]	过流一段投退 E.3I>>> [Enable.3I>>>]	0	0~1	退出; 投入 OFF; ON
	一段带方向 E.3I>>>.D[67] [Enable.3I>>> .direction]	0	0~2	不带方向; 指向线路; 指向 母线 OFF; Line; Bus
	一段经低压 E.3I>>>.U [Enable.3I>>> .Voltage]	0	0~1	退出; 投入 OFF; ON [If enable 3I>>>.U, voltage conditions should be considered for overcurrent protection. When the smallest of the three line voltages is less than U.Under and greater than U.Less, the overcurrent

				protection DO is prepare work.]
	过流一段定值 3I>>> [3I>>> value]	10A	0.04~100	
	过流一段延时 3I>>>.T [3I>>> delay]	0s	0~60	
过流二段 3I>> [51] [Time-limited overcurrent]	过流二段投退 E.3I>> [Enable.3I>>.]	0	0~1	退出；投入 OFF； ON
	二段带方向 E.3I>>.D[67] [Enable.3I>> .direction]	0	0~2	不带方向；指向线路；指向 母线 OFF； Line； Bus
	二段经低压 E.3I>>.U [Enable.3I>> .Voltage]	0	0~1	退出；投入 OFF； ON [If enable 3I>>.U, voltage conditions should be considered for overcurrent protection. When the smallest of the three line voltages is less than U.Under and greater than U.Less, the overcurrent protection DO is prepare work.]
	过流二段定值 3I>> [3I>> value]	7.5A	0.04~100	
	过流二段延时 3I>>.T [3I>> delay]	0.2s	0~60	
过流三段 3I> [51]	过流三段投退 E.3I> [Enable.3I>]	0	0~1	退出；投入 OFF； ON

[Definite time overcurrent]	三段带方向 E.3I>.D[67] [Enable.3I> .direction]	0	0~2	不带方向; 指向线路; 指向 母线 OFF; Line; Bus
	三段经低压 E.3I>.U [Enable.3I> .Voltage]	0	0~1	退出; 投入 OFF; ON [If enable 3I>.U, voltage conditions should be considered for overcurrent protection. When the smallest of the three line voltages is less than U.Under and greater than U.Less, the overcurrent protection DO is prepare work.]
	过流三段定值 3I> [3I> value]	7A	0.04~100	
	过流三段延时 3I>.T [3I> delay]	0.5s	0~60	
反时限过流 I>Inv [51] [Inverse time overcurrent (IDMT)]	反时限过流投退 E. I>.Inv [Enable I> Inverse]	0	0~1	退出; 投入 OFF; ON
	反时限经低压 E.I>.Inv.U [Enable I>Inverse voltage]	0	0~1	退出; 投入 OFF; ON [If enable I>.Inv.U, voltage conditions should be considered for overcurrent protection. When the smallest of the three line voltages is less than U.Under and greater than U.Less, the overcurrent protection DO is prepare

				work.]
	反时限启动电流 I>.Inv [Inverse current]	5A	0.04~100	
	反时限时间系数 I>.Inv.K [Inverse time coefficient]	0.1s	0.1~100	
	反时限曲线类型 I>.Inv.X [Inverse curves]	0	0~2	一般; 非常; 极端 NI; VI; EI
低电压保护一段 [27] Undervoltage Protection>>>	低电压一段投退 E.LVP>>> [Enable Undervoltage >>>]	0	0~2	退出; 告警; 跳闸 OFF; Alarm; Trip
	低电压一段定值 LVP>>> [Undervoltage >>> value]	50V	1~500	
	低电压一段延时 LVP.T>>> [Undervoltage >>> delay]	5s	0~999	
	一段无流闭锁 E.L.I.B>>> [Enable Undervoltage >>> current block]	0	0~1	退出; 投入 OFF; ON [If enable LVPI.B>>>, when the current is less than I.None, under voltage protection will be blocked.]
	一段 PT 断线闭锁 E.PT.B>>> [Enable PT break block>>>]	1	0~1	退出; 投入 OFF; ON [When PT break occurs, the relay will send an alarm signal and lock out the under voltage protection.]
	一段合位允许 E.CB On>>> [Enable circuit breaker on block>>>]	0	0~1	退出; 投入 OFF; ON

	一段低压阈值 E.LVThr.>>> [Enable Undervoltage threshold>>>]	1	0~1	退出; 投入 OFF; ON
低电压保护二段 [27] Undervoltage Protection>>	低电压二段投退 E.LVP>> [Enable Undervoltage >>]	0	0~1	退出; 告警; 跳闸 OFF; Alarm; Trip
	低电压二段定值 LVP>> [Undervoltage >> value]	50V	1~500	
	低电压二段延时 LVP.T>> [Undervoltage >> delay]	5s	0~60	
	二段无流闭锁 E.L.I.B>> [Enable Undervoltage >> current block]	0	0~1	退出; 投入 OFF; ON [If enable LVP.I.B>>, when the current is less than I.None, under voltage protection will be blocked.]
	二段 PT 断线闭锁 E.PT.B>> [Enable PT break block>>]	1	0~1	退出; 投入 OFF; ON [When PT break occurs, the relay will send an alarm signal and lock out the under voltage protection.]
	二段合位允许 E.CB On>> [Enable circuit breaker on block>>]	0	0~1	退出; 投入 OFF; ON
	二段低压阈值 E.LVThr.>> [Enable Undervoltage threshold>>]	1	0~1	退出; 投入 OFF; ON
过电压保护一段 [59]	过电压一段投退 E.OVP>>>	0	0~2	退出; 告警; 跳闸 OFF; Alarm; Trip

Overvoltage Protection>>>	[Enable Overvoltage >>>]			
	过电压一段定值 U.OVP>>> [Overvoltage >>> value]	120V	0~800	
	过电压一段延时 OVP.T>>> [Overvoltage >>> delay]	5s	0~999	
过电压保护二段 [59] Overvoltage Protection>>	过电压二段投退 E.OVP>> [Enable Overvoltage >>]	0	0~2	退出; 告警; 跳闸 OFF; Alarm; Trip
	过电压二段定值 U.OVP>> [Overvoltage >> value]	120V	0~800	
	过电压一段延时 OVP.T>> [Overvoltage >> delay]	5s	0~999	
低频减载一段 [81U] Under-Frequency Protection>>>	低频一段投退 E.Un.Fr>>>. [Enable Under Frequency>>>]	0	0~1	退出; 投入 OFF; ON
	一段低压闭锁 E.U.F>>>.U [Enable Under Frequency >>> voltage block]	0	0~1	退出; 投入 OFF;ON [If the maximum voltage is lower than U.B>>>, while the zero sequence voltage 3U0 is lower than 8V, or PT break , Under frequency function will be blocked.]
	一段欠流闭锁 E.U.F>>>.I [Enable Under Frequency >>> current block]	0	0~1	退出; 投入 OFF;ON [When the maximum current value is lower than I.B>>>, Under frequency function will be blocked.]
	一段滑差闭锁 E.UnF>>>.dHz. [Enable Under Frequency slip block]	0	0~1	退出; 投入 OFF;ON [When df/dt lower than dHz.B>>>, Under frequency function will be blocked.]
	低频一段定值	49Hz	45~60	

	UnderFr>>> [Under Frequency >>> value]			
	低频一段延时 Un.Fr>>>.T [Under Frequency >>> delay]	3s	0~60	
	一段滑差闭锁值 dHz.B>>> [Under Frequency>>> slip block value]	0.1Hz/s	0.1~10	
	一段欠流闭锁值 I.B>>> [Under Frequency>>> current block value]	5A	0.2~100	
	一段低压闭锁值 U.B>>> [Under Frequency>>>voltage block value]	50V	0~200	
低频减载二段 [81U] Under-Frequency Protection>>	低频二段投退 E.Un.Fr>>. [Enable Under Frequency>>]	0	0~1	退出; 投入 OFF; ON
	二段低压闭锁 E.U.F>>.U [Enable Under Frequency>>voltage block]	0	0~1	退出; 投入 OFF;ON [Ua is lower than U.B>>, while the zero sequence voltage 3U0 is lower than 8V, or PT break , Under frequency function will be blocked.]
	二段欠流闭锁 E.U.F>>.I [Enable Under Frequency>>current block]	0	0~1	退出; 投入 OFF;ON [When the maximum current value is lower than I.B>>,Under frequency function will be blocked.]
	二段滑差闭锁 E.UnF>>.dHz. [Enable Under Frequency>> slip block]	0	0~1	退出; 投入 OFF;ON [When df/dt lower than dHz.B>>, Under frequency function will be blocked.]

	低频二段定值 UnderFr>> [Under Frequency>> value]	49Hz	45~60	
	低频二段延时 Un.Fr>>.T [Under Frequency>> delay]	3s	0~60	
	二段滑差闭锁值 dHz.B>> [Under Frequency>> slip block value]	0.1Hz/s	0.1~10	
	二段欠流闭锁值 I.B>> [Under Frequency >> current block value]	5A	0.2~100	
	二段低压闭锁值 U. B>> [Under Frequency >> voltage block value]	50V	0~200	
高频一段保护 [81O] Over Frequency Protection>>>	高频一段投退 E.OF>>> [Enable Over Frequency >>>]	0	0~1	退出; 投入 OFF; ON
	高频一段定值 OF>>> [Over Frequency >>> value]	50Hz	40~70	
	高频一段延时 OF>>>.T [Over Frequency >>> delay]	5s	0~999	
高频二段保护 [81O] Over Frequency Protection>>	高频二段投退 E.OF>> [Enable Over Frequency >>]	0	0~1	退出; 投入 OFF; ON
	高频二段定值 OF>> [Over Frequency >> value]	50Hz	40~70	
	高频二段延时 OF>>.T	5s	0~999	

	[Over Frequency >> delay]			
频率突变跳闸 [81R] Rate Of Change Of Frequency	频率突变投退 E.Fr.Muta. [Enable Rate Of Change Of Frequency]	0	0~1	退出; 投入 OFF; ON
	频率突变定值 Fr.Muta. [Rate Of Change Of Frequency value]	0.1Hz/s	0.01~100	
	频率突变启动延时 Fr.S [Frrquency Start delay]	0.2s	0~3	
	频率突变延时 Fr.Muta.T [Rate Of Change Of Frequency delay]	0.4s	0~999	
	电流判断来源 I Source [Current judgment Source]	1	0~1	保护电流; 测量电流 Protective current; Measurment current
	有流定值 I.Set [Current setting]	0.1A	0.04~100	
	功率保护计算电压 P.U.S [Calculating voltage judgment source of power protection]	0	0~1	母线电压; 进线电压 Bus voltage;Incoming voltage
逆功率一段保护 [32R] Directional Power Protection>>>	逆功率一段投退 E.RP>>> [Enable Directional Power>>>]	0	0~1	退出; 投入 OFF; ON
	逆功率一段定值 RP>>> [Directional Power>>> Value]	0	0~1000000000	
	逆功率一段延时 RP>>>.T	0	0~999	

	[Directional Power>>> delay]			
逆功率二段保护 [32R] Directional Power Protection>>	逆功率二段投退 E.RP>> [Enable Directional Power>>]	0	0~1	退出; 投入 OFF; ON
	逆功率二段护定值 RP>> [Directional Power>> value]	0	0~1000000000	
	逆功率二段延时 RP>>.T [Directional Power>> delay]	0	0~999	
低功率一段 [37] Under power protection >>>	低功率一段投退 E.LP>>> [Enable Under power>>>]	0	0~1	退出; 投入 OFF; ON
	低功率一段定值 LP>>> [Under power>>> value]	0	0~1000000000	
	低功率一段门槛 LP.T>>> [Under power>>> threshold]	1	0~1000000000	
	低功率一段延时 LP>>>.T [Under power>>> delay]	0s	0~999	
低功率二段 [37] Under power protection>>	低功率二段投退 E.LP>> [Enable Under power>>]	0	0~1	退出; 投入 OFF; ON
	低功率二段定值 LP>> [Under power>> value]	0	0~1000000000	
	低功率二段门槛 LP.T>> [Under power>> threshold]	1	0~1000000000	
	低功率二段延时 LP>>.T [Under power>> delay]	0s	0~999	
功率恢复一段	功率恢复一段投退	0	0~1	退出; 投入

Power Recovery>>>	E.P>>> [Enable Power Recovery>>>]			OFF; ON
	功率恢复一段定值 P>>> [Power Recovery>>> value]	0	0~1000000000	
	功率恢复一段延时 P>>>.T [Power Recovery>>> delay]	0s	0~999	
功率恢复二段 Power Recovery>>	功率恢复二段投退 E.P>> [Enable Power Recovery>>]	0	0~1	退出; 投入 OFF; ON
	功率恢复二段定值 P>> [Power Recovery>>> value]	0	0~1000000000	
	功率恢复二段延时 P>>.T [Power Recovery>> delay]	0s	0~999	
	功率恢复返回延时 P.RT [Power Reset delay]	5s	0~999	
进线失压保护 Incoming Undervoltage Protection[27]	进线失压投退 E.NVP [Enable Incoming Undervoltage Protection]	0	0~2	退出; 告警; 跳闸 OFF; Alarm; Trip
	进线失压定值 NVP [Incoming Undervoltage Protection value]	50V	1~500	
	进线失压延时 NVP.T [Incoming Undervoltage Protection delay]	5s	0~999	
	进线失压无流闭锁 E.NIB [Enable Incoming	0	0~1	退出; 投入 OFF; ON [If enable NIB, when the

	Undervoltage with current block]			current is less than I.None, incoming undervoltage protection will be blocked.]
	失压 PT 断线闭锁 E.PTB [Enable PT break block]	1	0~1	退出; 投入 OFF; ON [When PT break occurs, the relay will send an alarm signal and lock out the incoming under voltage protection.]
	进线失压合位允许 E.CBOn [Enable circuit breaker on block]	0	0~1	退出; 投入 OFF; ON
有压自动合闸 Auto-Close with voltage recovery	有压电压来源 U Source [Voltage Source]	1	0~1	母线电压; 进线电压 Bus voltage; Incoming voltage
	有压自动合闸投退 E.U.C [Enable Auto-Close with voltage recovery]	0	0~1	退出; 投入 OFF; ON
	有压合闸电压上限 U.U.C [Auto-Close with voltage recovery upper limit]	410V	0~9999	
	有压合闸电压下限 U. D.C [Auto-Close with voltage recovery down limit]	260V	0~9999	
	有压自动合闸延时 U. C.T [Auto-Close with voltage recovery delay]	0.4s	0~999	
	有压合闸频率上限 Fr.U.U	50Hz	40~70	

	[Auto-Close with voltage recovery Frequency upper limit]			
	有压合闸频率下限 Fr.U.D [Auto-Close with voltage recovery Frequency down limit]	49.8Hz	40~70	
	进线合位允许 E.In.C On. [Enable Incoming circuit breaker on]	0	0~1	退出; 投入 OFF; ON
	同期允许投退 E.SameP.A. [Enable Synchro-Check Allowed]	0	0~1	退出; 投入 OFF; ON
	录波选择 Record.S [Record Selection]	0	0~1	同期录波; 有压合闸录波 Same.P; U.C.
检同期 [25] Synchro-Check	同期控制字 E.SameP. [Enable Synchro-Check]	0	0~1	退出; 投入 OFF; ON
	同期稳定延时 SameP.StaT [Synchro-Check Stabilization delay]	0.2s	0~999.999	
	同期对象类型 SameP.Type [Synchro-Check type]	1	0~1	差频(准同期合闸); 同频(环网合闸) Dif.Fr; Same.Fr [Differential Frequency; Same Frequency]
	系统侧通道号 Sy.CH [System Channel]	12	0~14	

	系统侧一次电压 SyPr.U [System Side Primary Voltage]	10kV	0~9999	
	系统侧 PT 一次值 SyPT.Pr [System Side PT Primary Voltage]	10kV	0~9999	
	系统侧 PT 二次值 SyPT.Se [System Side PT Secondary Voltage]	100V	0~9999	
	待并侧通道号 Gr.C.CH [Generator voltage Channel]	7	0~14	
	待并侧一次电压 GrC.PriU [Generator Primary voltage]	10kV	0~9999	
	待并侧 PT 一次值 GrC.PTPr [Generator PT Primary Voltage]	10kV	0~9999	
	待并侧 PT 二次值 GrC.PTSe [Generator PT Secondary Voltage]	100V	0~9999	
	允许正压差% Po.U.Dif% [Poaitive voltage difference allowed]	5%	0~30	
	允许负压差% Ne.U.Dif% [Negative voltage difference allowed]	5%	0~30	
	额定频率 Rated Fr	50Hz	40~70	

	[Rated Frequency]			
	系统侧频率偏差 Sy.Fr.Di [System Frequency difference]	0.1Hz	0~5	
	待并侧频率偏差 GrC.FrDi [Generator Frequency difference]	0.1Hz	0~5	
	允许正频差 Po.Fr.Di [Positive Frequency difference allowed]	0.1Hz	0~5	
	允许负频差 Ne.Fr.Di [Negative Frequency difference allowed]	0.1Hz	0~5	
	允许频差加速度 Fr.Dif.A [Frequency difference accelation allowed]	1Hz/s	0~10	
	同频并网相角差 SaFr.PhD [Same Frequency Phase Angle difference]	5°	0~60	
	差频并网相角差 DiFr.PhD [Difference Frequency Phase Angle difference]	5°	0~60	
	系统侧相角补偿 Sys.Ph.C [System Phase Angle Compensation]	0°	0~330	
	同期导前时间 SameP.Le.T [Synchronism Lead Time]	0.1s	0.02~999	

过负荷告警 I>Lo.A [49F] Overload Alarm	过负荷告警投退 E.I>Lo.A [Enable Overload Alarm]	0	0~1	退出；投入 OFF；ON
	过负荷告警定值 I>Lo.A [Overload Alarm value]	6.5A	0.04~100	
	过负荷告警延时 I>Lo.A.T [Overload Alarm delay]	5s	0~999	
过负荷跳闸 I>Lo.T [49F] Overload Trip	过负荷跳闸投退 E.I>Lo.T [Enable Overload Trip]	0	0~1	退出；投入 OFF；ON
	过负荷跳闸定值 I>Lo.T [Overload Trip value]	6A	0.04~100	
	过负荷跳闸延时 I>Lo.T.T [Overload Trip delay]	10s	0~60	
	I0 电流来源 I0 Source	0	0~1	自产；外接通道 2 Self-produced;CH2
I0 过流一段 I0>>> [50N] [Instantaneous ground fault overcurrent]	I0 一段投退 E.I0>>> [Enable I0>>>]	0	0~1	退出；投入 OFF；ON
	I0 一段带方向 E.I0>>>D[67N] [Enable I0>>> direction]	0	0~2	不带方向；指向线路；指向 母线 OFF；Line；Bus
	I0 一段定值 I0>>> [I0>>> value]	10A	0.04~100	
	I0 一段延时 I0>>>.T [I0>>> delay]	5s	0~60	
	I0 一段 3U0 值 I0>>>.3U0	2V	0~200	
I0 过流二段	I0 二段投退	0	0~2	退出；告警；跳闸

I0>> [51N] [Time limited ground fault overcurrent]	E.I0>> [Enable I0>>]			OFF; Alarm; Trip
	I0 二段带方向 E.I0>>D[67N] [Enable I0>> direction]	0	0~2	不带方向; 指向线路; 指向 母线 OFF; Line; Bus
	I0 二段定值 I0>> [I0>> value]	9A	0.04~100	
	I0 二段延时 I0>>.T [I0>> delay]	10s	0~60	
	I0 二段 3U0 值 I0>>.3U0	2V	0~200	
PT 断线告警 PT supervision[60]	PT 断线告警投退 E.PtBr.A [Enable PT break alarm]	0	0~1	退出; 投入 OFF; ON
	PT 断线告警延时 PtBr.T [PT break alarm delay]	10s	0~999	
	无压定值 U.None [No-voltage]	15V	0~200	[Less than U.None means that there is no voltage]
	无流定值 I.None [No-Current]	0.2A	0.04~100	[Less than I.None means that there is no current]
	PT 断线负序电压 U2.Pt [PT break negative sequence voltage]	35V	0~200	
控故障告警 Trip and close circuit supervision alarm	控故障告警投退 E.CB.A [Enable Trip and close circuit supervision alarm]	0	0~1	退出; 投入 OFF; ON
	控故障告警延时 CB.A.T [Trip and close circuit supervision alarm delay]	10s	0~999	

FC 配合的过流闭锁 功能 FC Block	FC 闭锁投退 E.FCBlock [Enable FC Block]	0	0~1	退出；投入 OFF；ON
	FC 闭锁电流定值 FCB.I [FC Block current value]	10A	0.04~100	
	FC 闭锁延时 FCB.T [FC Block delay]	5s	0~60	
I0 反时限过流 I0.Inv [51N] [Inverse time ground fault]	I0 反时限投退 E. I0.Inv [Enable I0.Inverse]	0	0~1	退出；投入 OFF；ON
	I0 反时限启动值 I0.Inv [I0.Inverse value]	5A	0.04~100	
	I0 反时限系数 I0.Inv.K [I0.Inverse time coefficient]	0.5s	0~100	
	I0 反时限曲线 I0.Inv.X [I0.Inverse curves]	0	0~2	一般；非常；极端 NI；VI；EI
零序过压保护 U0 OVP [59N] [Residual over voltage]	零序过压投退 E.U0.OVP [Enable Residual over voltage]	0	0~2	退出；告警；跳闸 OFF；Alarm；Trip
	零序过压定值 U0.OVP [Residual over voltage value]	20V	0~500	
	零序过压延时 U0.OVP.T [Residual over voltage delay]	5s	0~999	
非电量 1 保护 Non-electricity1 protection	非电量 1 投退 E. Non-e11 [Enable Non-e11]	0	0~1	退出；投入 OFF；ON
	非电量 1 方式 E. Non-e11.M [Enable Non-electricity1 Mode]	0	0~1	告警；跳闸 Alarm；Trip
	非电量 1 延时 Non-e11.T	1s	0~999	

	[Non-electricity1 delay]			
非电量 2 保护 Non-electricity2 protection	非电量 2 投退 E. Non-el2 [Enable Non-electricity2]	0	0~1	退出; 投入 OFF; ON
	非电量 2 方式 E. Non-el2.M [Enable Non-electricity2 Mode]	0	0~1	告警; 跳闸 Alarm; Trip
	非电量 2 延时 Non-el2.T [Non-electricity2 delay]	1s	0~999	
	跳闸内部时间 Default.T [Trip Default Time]	0s	0~999	
	事故总信号延时 Acci.S.T [Accident Signal delay]	0.3s	0~999	
	EMC 闭锁投退 E.EMC.B [Enable EMC Block]	1	0~1	退出; 投入 OFF; ON
	断路器位置采集 CB Po.Ac [Circuit Breaker position Collection]	1	0~1	辅助触点; 分合位监视 Auxiliary.C;CB M. [Auxiliary contact;Circuit Breaker Monitor]
	断路器动作时间 Cir.Br.T [Circuit Breaker time]	0.3s	0~999	
	弹簧未储能延时 Sp.En.D. [Discharge delay]	0s	0~999	
	过量返回系数 Excess R.C [Excess Return Coefficient]	0.95	0.001~1	
	欠量返回系数 Under R.C [Under Return Coefficient]	1.05	1~2	
CT 断线告警 CT supervision[60]	CT 断线告警投退 E.CTBr.A	0	0~1	退出; 投入 OFF; ON

	[Enable CT Break Alarm]			
	CT 断线无流定值 CTBr.I.N [CT Break No-Current]	0.125A	0.04~100	
	CT 断线有流定值 CTBr.I.S [CT Break Current setting]	0.2A	0.04~100	
	CT 断线告警延时 CTBr.T [CT Break Alarm time]	5s	0~999	
检修状态闭锁 Over haul- block	检修状态闭锁通讯投退 E. M.BC [Enable Overhaul-lockout communication]	0	0~1	退出；投入 OFF； ON
	检修状态闭锁出口投退 E. M.BE [Enable Overhaul-lockout DO]	0	0~1	退出；投入 OFF； ON
	频率过返系数 Exc Fr.R.C [Excess Frequency return coefficient]	0.995	0.001~1	
	频率欠返系数 Und Fr.R.C [Under Frequency return coefficient]	1.005	1.000~2	
	事故总信号投退 E.Acci.S [Enable Accident Signal]	0	0~1	退出；投入 OFF； ON
	合位动作延时 CB.T [Circuit Breaker action delay]	3s	0~999	
	跳闸展宽 Tripping pulse	0.3s	0~1	

AM5SE-FE 定值表				
AM5SE-FE Setting				
保护名称 Protection Name	定值名称 Value Name	默认值 Default	范围 Range	备注 Remark
	CT 变比 CT	10	0.1~9999	
	PT 变比 PT	100	0.1~9999	
	一次电压显示 U Unit [Primary voltage display]	0	0~1	kV;V
	电压接线方式 PT Mode [Voltage measurement mode]	0	0~1	3PT; 2PT
	保护电流接线方式 P.CT Mode [Protective CT Mode]	0	0~1	3CT; 2CT
	测量电流接线方式 M.CT Mode [Measurment CT Mode]	0	0~1	3CT; 2CT
低电压保护一段 [27] Undervoltage Protecion>>>	低电压一段投退 E.LVP>>> [Enable Undervoltage >>>]	0	0~2	退出; 告警; 跳闸 OFF; Alarm; Trip
	低电压一段定值 LVP>>> [Undervoltage >>> value]	50V	1~500	
	低电压一段延时 LVP.T>>> [Undervoltage >>> delay]	5s	0~999	
	一段无流闭锁 E.L.I.B>>> [Enable Undervoltage >>> current block]	0	0~1	退出; 投入 OFF; ON [If enable LVP.I.B>>>, when the current is less than I.None, under voltage protection will be

				blocked.]
	一段 PT 断线闭锁 E.PT.B>>> [Enable PT break block>>>]	1	0~1	退出; 投入 OFF; ON [When PT break occurs, the relay will send an alarm signal and lock out the under voltage protection.]
	一段合位允许 E.CB On>>> [Enable circuit breaker on block>>>]	0	0~1	退出; 投入 OFF; ON
	一段低压阈值 E.LVThr.>>> [Enable Undervoltage threshold>>>]	1	0~1	退出; 投入 OFF; ON
低电压保护二段 [27] Undervoltage Proteccion>>	低电压二段投退 E.LVP>> [Enable Undervoltage >>]	0	0~2	退出; 告警; 跳闸 OFF; Alarm; Trip
	低电压二段定值 LVP>> [Undervoltage >> value]	50V	1~500	
	低电压二段延时 LVP.T>> [Undervoltage >> delay]	5s	0~999	
	二段无流闭锁 E.L.I.B>> [Enable Undervoltage >> current block]	0	0~1	退出; 投入 OFF; ON [If enable LVP.I.B>>, when the current is less than I.None, under voltage protection will be blocked.]
	二段 PT 断线闭锁 E.PT.B>> [Enable PT break block>>]	1	0~1	退出; 投入 OFF; ON [When PT break occurs, the relay will send an alarm

				signal and lock out the under voltage protection.]
	二段合位允许 E.CB On>> [Enable circuit breaker on block>>]	0	0~1	退出; 投入 OFF; ON
	二段低压阈值 E.LVThr.>> [Enable Undervoltage threshold>>]	1	0~1	退出; 投入 OFF; ON
过电压保护一段 [59] Overvoltage Protection>>>	过电压一段投退 E.OVP>>> [Enable Overvoltage >>>]	0	0~2	退出; 告警; 跳闸 OFF; Alarm; Trip
	过电压一段定值 U.OVP>>> [Overvoltage >>> value]	120V	0~800	
	过电压一段延时 OVP.T>>> [Overvoltage >>> delay]	5s	0~999	
过电压保护二段 [59] Overvoltage Protection>>	过电压二段投退 E.OVP>> [Enable Overvoltage >>]	0	0~2	退出; 告警; 跳闸 OFF; Alarm; Trip
	过电压二段定值 U.OVP>> [Overvoltage >> value]	120V	0~800	
	过电压一段延时 OVP.T>> [Overvoltage >> delay]	5s	0~999	
低频减载一段 [81U] Under-Frequency Protection>>>	低频一段投退 E.Un.Fr>>>. [Enable Under Frequency>>>]	0	0~1	退出; 投入 OFF; ON
	一段低压闭锁 E.U.F>>>.U [Enable Under	0	0~1	退出; 投入 OFF;ON [Ua is lower than U.B>>>], while the self-produced

	Frequency >>> voltage block]			zero sequence voltage 3U0 is lower than 8V, or PT break, Under frequency function will be blocked.]
	一段欠流闭锁 E.U.F>>>.I [Enable Under Frequency >>> current block]	0	0~1	退出; 投入 OFF;ON [When the maximum current value is lower than I.B>>>,Under frequency function will be blocked.]
	一段滑差闭锁 E.UnF>>>.dHz. [Enable Under Frequency slip block]	0	0~1	退出; 投入 OFF;ON [When df/dt lower than dHz.B>>>, Under frequency function will be blocked.]
	低频一段定值 UnderFr>>> [Under Frequency >>> value]	49Hz	45~60	
	低频一段延时 Un.Fr>>>.T [Under Frequency >>> delay]	3s	0~60	
	一段滑差闭锁值 dHz.B>>> [Under Frequency>>> slip block value]	0.1Hz/s	0.1~10	
	一段欠流闭锁值 I.B>>> [Under Frequency>>> current block value]	5A	0.2~100	
	一段低压闭锁值 U.B>>> [Under Frequency>>> voltage block value]	50V	0~200	
低频减载二段 [81U] Under-Frequency Protection>>	低频二段投退 E.Un.Fr>>. [Enable Under Frequency>>]	0	0~1	退出; 投入 OFF; ON
	二段低压闭锁	0	0~1	退出; 投入 OFF;ON

	E.U.F>>.U [Enable Under Frequency>>voltage block]			[Ua is lower than U.B>>, while the zero sequence voltage 3U0 is lower than 8V, or PT break , Under frequency function will be blocked.]
	二段欠流闭锁 E.U.F>>.I [Enable Under Frequency>>current block]	0	0~1	退出; 投入 OFF;ON [When the maximum current value is lower than I.B>>,Under frequency function will be blocked.]
	二段滑差闭锁 E.UnF>>.dHz. [Enable Under Frequency>> slip block]	0	0~1	退出; 投入 OFF;ON [When df/dt lower than dHz.B>>, Under frequency function will be blocked.]
	低频二段定值 UnderFr>> [Under Frequency>> value]	49Hz	45~60	
	低频二段延时 Un.Fr>>.T [Under Frequency>> delay]	3s	0~60	
	二段滑差闭锁值 dHz.B>> [Under Frequency>> slip block value]	0.1Hz/s	0.1~10	
	二段欠流闭锁值 I.B>> [Under Frequency >> current block value]	5A	0.2~100	
	二段低压闭锁值 V. B>> [Under Frequency >> voltage block value]	50V	0~200	
高频一段保护 [81O] Over Frequency	高频一段投退 E.OF>>>> [Enable Over Frequency>>>>]	0	0~1	退出; 投入 OFF; ON

Protection>>>	高频一段定值 OF>>> [Over Frequency>>> value]	50Hz	40~70	
	高频一段延时 OF>>>.T [Over Frequency>>> delay]	5s	0~999	
高频二段保护 [81O] Over Frequency Protection>>	高频二段投退 E.OF>> [Enable Over Frequency>>]	0	0~1	退出; 投入 OFF; ON
	高频二段定值 OF>> [Over Frequency>> value]	50Hz	40~70	
	高频二段延时 OF>>.T [Over Frequency>> delay]	5s	0~999	
频率突变跳闸 [81R] Rate Of Change Of Frequency	频率突变投退 E.Fr.Muta. [Enable Rate Of Change Of Frequency]	0	0~1	退出; 投入 OFF; ON
	频率突变定值 Fr.Muta. [Rate Of Change Of Frequency value]	0.1Hz/s	0.01~100	
	频率突变启动延时 Fr.S [Frrquency Start delay]	0.2s	0~3	
	频率突变延时 Fr.Muta.T [Rate Of Change Of Frequency delay]	0.4s	0~999	
	电流判断来源 I Source [Current judgment Source]	1	0~1	保护电流; 测量电流 Protective current; Measurement current
	有流定值 I.Set	0.1A	0.04~100	

	[Current setting]			
PT 断线告警 PT supervision[60]	PT 断线告警投退 E.PtBr.A [Enable PT Break alarm]	0	0~1	退出; 投入 OFF; ON
	PT 断线告警延时 PtBr.T [PT Break alarm delay]	10s	0~999	
	无压定值 U.None [No-Voltage]	15V	0~200	[Less than U.None means that there is no voltage]
	无流定值 I.None [No-Current]	0.2A	0.04~100	[Less than I.None means that there is no current]
	PT 断线负序电压 U2.Pt [PT break negative sequence voltage]	35V	0~200	
控故障告警 Trip and close circuit supervision	控故障告警投退 E.CB.A [Enable Trip and close circuit supervision alarm]	0	0~1	退出; 投入 OFF; ON
	控故障告警延时 CB.A.T [Trip and close circuit supervision alarm delay]	10s	0~999	
	跳闸内部时间 Default.T [Trip Default Time]	0s	0~999	
	事故总信号延时 Acci.S.T [Accident Signal delay]	0.3s	0.01~60	
	EMC 闭锁投退 E.EMC.B [Enable EMC Block]	1	0~1	退出; 投入 OFF; ON
	断路器位置采集 CB Po.Ac [Circuit Breaker position]	1	0~1	辅助触点; 分合位监视 Auxiliary.C;CB M. [Auxiliary contact;Circuit

	Collection]			Breaker Monitor]
	断路器动作时间 Cir.Br.T [Circuit Breaker time]	0.3s	0~999	
	弹簧未储能延时 Sp.En.D. [Discharge delay]	0s	0~999	
	过量返回系数 Excess R.C [Excess Return Coefficient]	0.95	0.001~1	
	欠量返回系数 Under R.C [Under Return coefficient]	1.05	1~2	
检修状态闭锁 Over haul- block	检修状态闭锁通讯投退 E. M.BC [Enable Overhaul-lockout communication]	0	0~1	退出；投入 OFF； ON
	检修状态闭锁出口投退 E. M.BE [Enable Overhaul-lockout DO]	0	0~1	退出；投入 OFF； ON
	频率过返系数 Exc Fr.R.C [Excess Frequency return coefficient]	0.995	0.001~1	
	频率欠返系数 Und Fr.R.C [Under Frequency return coefficient]	1.005	1.000~2	
	跳闸展宽 Tripping pulse	0.3s	0~1	

AM5SE-FA 定值表 AM5SE-FA Setting				
保护名称 Protection Name	定值名称 Value Name	默认值 Default	范围 Range	备注 Remark
	CT 变比	10	0.1~9999	

	CT			
	PT 变比 PT	100	0.1~9999	
	一次电压显示 U Unit [Primary voltage display]	0	0~1	kV;V
	电压接线方式 PT Mode [Voltage measurement mode]	0	0~1	3PT; 2PT
	保护电流接线方式 P.CT Mode [Protective CT Mode]	0	0~1	3CT; 2CT
	测量电流接线方式 M.CT Mode [Measurment CT Mode]	0	0~1	3CT; 2CT
	电流判断来源 I Source [Current judgment Source]	0	0~1	保护电流; 测量电流 Protective current; Measurement current
	有流定值 I Set [Current setting]	0.5A	0.04~100	
	无流定值 I.None [No-Current]	0.2A	0.04~100	[Less than I.None means that there is no current]
	无流闭锁 E.L.I.B>>>> [Enable current block]	0	0~1	退出; 投入 OFF; ON [If enable L.I.B, when the current is less than I.None, protection will be blocked.]
	合位允许 E.CB On>>>> [Enable circuit breaker on block]	0	0~1	退出; 投入 OFF; ON
低电压保护一段	低电压一段投退	0	0~2	退出; 告警; 跳闸

[27] Undervoltage Proteccion>>>	E.LVP>>> [Enable Undervoltage >>>]			OFF; Alarm; Trip
	低电压一段定值 LVP>>> [Undervoltage >>> value]	50V	1~500	
	低电压一段延时 LVP.T>>> [Undervoltage >>> delay]	5s	0~999	
	一段 PT 断线闭锁 E.PT.B>>> [Enable PT break block>>>]	1	0~1	退出; 投入 OFF; ON
	一段低压阈值 E.LVThr.>>> [Enable Undervoltage threshold>>>]	1	0~1	退出; 投入 OFF; ON
低电压保护二段 [27] Undervoltage Proteccion>>	低电压二段投退 E.LVP>> [Enable Undervoltage >>]	0	0~1	退出; 告警; 跳闸 OFF; Alarm; Trip
	低电压二段定值 LVP>> [Undervoltage >> value]	50V	1~500	
	低电压二段延时 LVP.T>> [Undervoltage >> delay]	5s	0~60	
	二段 PT 断线闭锁 E.PT.B>> [Enable PT break block>>]	1	0~1	退出; 投入 OFF; ON
	二段低压阈值 E.LVThr.>> [Enable Undervoltage threshold>>]	1	0~1	退出; 投入 OFF; ON
过电压保护一段 [59] Overvoltage Protection>>>	过电压一段投退 E.OVP>>> [Enable Overvoltage >>>]	0	0~1	退出; 投入 OFF; ON
	过电压一段定值	120V	0~800	

	U.OVP>>> [Overvoltage >>> value]			
	过电压一段延时 OVP.T>>> [Overvoltage >>> delay]	5s	0~999	
过电压保护二段 [59] Over Voltage Protection>>>	过电压二段投退 E.OVP>> [Enable Overvoltage >>]	0	0~1	退出; 投入 OFF; ON
	过电压二段定值 U.OVP>> [Overvoltage >> value]	120V	0~800	
	过电压一段延时 OVP.T>> [Overvoltage >> delay]	5s	0~999	
低频减载一段 [81U] Under-Frequency Protection>>>>	低频一段投退 E.Un.Fr>>>. [Enable Under Frequency>>>]	0	0~1	退出; 投入 OFF; ON
	一段低压闭锁 E.U.F>>>.U [Enable Under Frequency >>> voltage block]	0	0~1	退出; 投入 OFF; ON [Ua is lower than U.B, while the zero sequence voltage 3U0 is lower than 8V, or PT break , Under frequency function will be blocked.]
	一段滑差闭锁 E.UnF>>>.dHz. [Enable Under Frequency>>> slip block]	0	0~1	退出; 投入 OFF; ON
	低频一段定值 UnderFr>>> [Under Frequency >>> value]	49Hz	45~60	
	低频一段延时	3s	0~60	

	Un.Fr>>>.T [Under Frequency >>> delay]			
	一段滑差闭锁值 dHz.B>>> [Under Frequency>>>> slip block value]	0.1Hz/s	0.1~10	
	一段低压闭锁值 U.B>>> [Under Frequency>>>> voltage block value]	50V	0~200	
低频减载二段 [81U] Under-Frequency Protection>>	低频二段投退 E.Un.Fr. [Enable Under Frequency >>]	0	0~1	退出; 投入 OFF; ON
	二段低压闭锁 E.U.F>>.U [Enable Under Frequency >> voltage block]	0	0~1	退出; 投入 OFF; ON
	二段滑差闭锁 E.UnF>>.dHz. [Enable Under Frequency>>>> slip block]	0	0~1	退出; 投入 OFF; ON
	低频二段定值 UnderFr>> [Under Frequency>>> value]	49Hz	45~60	
	低频二段延时 Un.Fr>>.T [Under Frequency>>> delay]	3s	0~60	
	二段滑差闭锁值 dHz.B>>> [Under Frequency>>>> slip block value]	0.1Hz/s	0.1~10	
	二段低压闭锁值 U.B>>>	50V	0~200	

	[Under Frequency>> voltage block value]			
高频一段保护 [81O] Over Frequency Protection>>>	高频一段投退 E.OF>>> [Enable Over Frequency>>>]	0	0~1	退出; 投入 OFF; ON
	高频一段定值 OF>>> [Over Frequency>>> value]	50Hz	40~70	
	高频一段延时 OF>>>.T [Over Frequency>>> delay]	5s	0~999	
高频二段保护 [81O] Over Frequency Protection>>	高频二段投退 E.OF>> [Enable Over Frequency>>]	0	0~1	退出; 投入 OFF; ON
	高频二段定值 OF>> [Over Frequency>> value]	50Hz	40~70	
	高频二段延时 OF>>.T [Over Frequency>> delay]	5s	0~999	
零序过压一段保护 U0.OVP>>> [59N] [Residual over voltage>>>]	U0 过压一段投退 E.U0>>> [Enable Residual over voltage>>>]	0	0~1	退出; 投入 OFF; ON
	U0 过压一段定值 U0.O>>> [Residual over voltage>>> value]	20V	0~800	
	U0 过压一段延时 U0>>>.T [Residual over voltage>>> delay]	5s	0~999	
零序过压二段保护 U0.OVP>> [59N]	U0 过压二段投退 E.U0>> [Enable Residual over	0	0~1	退出; 投入 OFF; ON

[Residual over voltage>>]	voltage>>]			
	U0 过压二段定值 U0.O>> [Residual over voltage>> value]	20V	0~800	
	U0 过压二段延时 U0>>.T [Residual over voltage>> delay]	5s	0~999	
PT 断线告警 PT supervision[60]	PT 断线告警投退 E.PtBr.A [Enable PT Break alarm]	0	0~1	退出; 投入 OFF; ON
	PT 断线告警延时 PtBr.T [PT Break delay]	10s	0~999	
	无压定值 U.None [No-Voltage]	15V	0~200	[Less than U.None means that there is no voltage]
	PT 断线负序电压 U2.Pt [PT break negative sequence voltage]	35V	0~200	
控故障告警 Trip and close circuit supervision	控故障告警投退 E.CB.A [Enable Trip and close circuit supervision alarm]	0	0~1	退出; 投入 OFF; ON
	控故障告警延时 CB.A.T [Trip and close circuit supervision alarm delay]	10s	0~999	
	跳闸内部时间 Default.T [Trip Default Time]	0s	0~999	
	事故总信号延时 Acci.S.T [Accident Signal delay]	0.3s	0.01~60	
	EMC 闭锁投退	1	0~1	退出; 投入

	E.EMC.B [Enable EMC Block]			OFF; ON
	断路器位置采集 CB Po.Ac [Circuit Breaker position Collection]	1	0~1	辅助触点; 分合位监视 Auxiliary.C;CB M. [Auxiliary contact;Circuit Breaker Monitor]
	断路器动作时间 Cir.Br.T [Circuit Breaker time]	0.3s	0~999	
	弹簧未储能延时 Sp.En.D. [Discharge delay]	0s	0~999	
	过量返回系数 Excess R.C [Excess Return coefficient]	0.95	0.001~1	
	欠量返回系数 Under R.C [Under Return coefficient]	1.05	1~2	
检修状态闭锁 Over haul- block	检修状态闭锁通讯投退 E. M.BC [Enable Overhaul-lockout communication]	0	0~1	退出; 投入 OFF; ON
	检修状态闭锁出口投退 E. M.BE [Enable Overhaul-lockout DO]	0	0~1	退出; 投入 OFF; ON
	频率过返系数 Exc Fr.R.C [Excess Frequency return coefficient]	0.995	0.001~1	
	频率欠返系数 Und Fr.R.C [Under Frequency return coefficient]	1.005	1.000~2	
	跳闸展宽 Tripping pulse	0.3s	0~1	
	分合位采集 CB On/Off A.	0	0~2	分合双点; 合位单点; 分位单点

	[Circuit Breaker On/Off Acquisition]			CCB On/Off; CCB On; CCB Off [Circuit Breaker On/Off; Circuit Breaker On; Circuit Breaker Off]
--	--	--	--	---

AM5SE-K 定值表 AM5SE-K Setting				
保护名称 Protection Function	定值名称 Value Name	默认值 Default	范围 Range	备注 Notice
	CT 变比 CT	10	0.1~9999	
	PT 变比 PT	100	0.1~9999	
	电压接线方式 PT Mode [Voltage measurement mode]	0	0~1	3PT; 2PT
	电流接线方式 CT Mode [Current measurement mode]	0	0~1	3CT; 2CT
	一次电压显示 U Unit [Primary voltage display]	0	0~1	kV;V
	遥控脉宽 Remote pulse	2000	0~999999999	

Appendix B Relay Event

AM 事件记录 AM Event Record				
事件代码 Event code	事件名称 Event name	参数名称 Parameter name	参数值 Parameter values	参数单位 Parameter unit
0	过流一段保护 [Instantaneous overcurrent] 3I>>>	A 相电流 Ia	浮点数 Float	A
		B 相电流 Ib	浮点数 Float	A
		C 相电流 Ic	浮点数 Float	A
		UAB	浮点数 Float	V
		UBC	浮点数 Float	V
		UCA	浮点数 Float	V
		负序电压 Negative sequence voltage U2	浮点数 Float	V
		A 相二次谐波电流 Ia Second Harmonic Ia_H2	浮点数 Float	A
		B 相二次谐波电流 Ib Second Harmonic Ib_H2	浮点数 Float	A
		C 相二次谐波电流 Ic Second Harmonic Ic_H2	浮点数 Float	A
1	过流二段保护 [Time-limited overcurrent] 3I>>	A 相电流 Ia	浮点数 Float	A
		B 相电流 Ib	浮点数 Float	A
		C 相电流 Ic	浮点数 Float	A
		UAB	浮点数 Float	V
		UBC	浮点数 Float	V
		UCA	浮点数 Float	V

		负序电压 Negative sequence voltage U2	浮点数 Float	V
		A 相二次谐波电流 Ia Second Harmonic Ia_H2	浮点数 Float	A
		B 相二次谐波电流 Ib Second Harmonic Ib_H2	浮点数 Float	A
		C 相二次谐波电流 Ic Second Harmonic Ic_H2	浮点数 Float	A
2	过流三段保护 [Definite time overcurrent] 3I>	A 相电流 Ia	浮点数 Float	A
		B 相电流 Ib	浮点数 Float	A
		C 相电流 Ic	浮点数 Float	A
		UAB	浮点数 Float	V
		UBC	浮点数 Float	V
		UCA	浮点数 Float	V
		负序电压 Negative sequence voltage U2	浮点数 Float	V
		A 相二次谐波电流 Ia Second Harmonic Ia_H2	浮点数 Float	A
		B 相二次谐波电流 Ib Second Harmonic Ib_H2	浮点数 Float	A
		C 相二次谐波电流 Ic Second Harmonic Ic_H2	浮点数 Float	A
3	启动时过流一段保护 [Motor Start Instantaneous overcurrent] 3I>>>.S	A 相电流 Ia	浮点数 Float	A
		B 相电流 Ib	浮点数 Float	A
		C 相电流 Ic	浮点数 Float	A

4	运行时过流一段保护 [Motor Run Instantaneous overcurrent] 3I>>>.R	A 相电流 Ia	浮点数 Float	A
		B 相电流 Ib	浮点数 Float	A
		C 相电流 Ic	浮点数 Float	A
5	A 相反时限过流保护 [Ia Inverse Definite Minimum Time overcurrent] Ia>InverseT.	时间 t	浮点数	s
		A 相电流 Ia	浮点数 Float	A
		B 相电流 Ib	浮点数 Float	A
		C 相电流 Ic	浮点数 Float	A
		UAB	浮点数 Float	V
		UBC	浮点数 Float	V
		UCA	浮点数 Float	V
负序电压 Negative sequence voltage U2	浮点数 Float	V		
6	B 相反时限过流保护 [Ib Inverse Definite Minimum Time overcurrent] Ib>InverseT.	时间 t	浮点数	s
		A 相电流 Ia	浮点数 Float	A
		B 相电流 Ib	浮点数 Float	A
		C 相电流 Ic	浮点数 Float	A
		UAB	浮点数 Float	V
		UBC	浮点数 Float	V
		UCA	浮点数 Float	V
负序电压 Negative sequence voltage U2	浮点数 Float	V		
7	C 相反时限过流保护	时间	浮点数	s

	[Ic Inverse Definite Minimum Time overcurrent] Ic>InverseT.	t		
		A 相电流 Ia	浮点数 Float	A
		B 相电流 Ib	浮点数 Float	A
		C 相电流 Ic	浮点数 Float	A
		UAB	浮点数 Float	V
		UBC	浮点数 Float	V
		UCA	浮点数 Float	V
		负序电压 Negative sequence voltage U2	浮点数 Float	V
8	I01 过流一段 [I01 ground fault Instantaneous overcurrent] I01>>>	I01	浮点数 Float	A
9	I01 过流二段 [I01 ground fault Time-limited overcurrent] I01>>	I01	浮点数 Float	A
10	I02 过流一段 [I02 ground fault Instantaneous overcurrent] I02>>>	I02	浮点数 Float	A
11	I02 过流二段 [I02 ground fault Time-limited overcurrent] I02>>	I02	浮点数 Float	A
12	I01 反时限 [I01 ground fault Inverse Definite Minimum Time overcurrent] I01>InverseT.	时间 t	浮点数 Float	s
		I01	浮点数 Float	A
13	I02 反时限 [I02 ground fault Inverse Definite Minimum Time overcurrent] I02>InverseT.	时间 t	浮点数 Float	s
		I02	浮点数 Float	A

14	后加速过流保护 [Post-accelerated overcurrent] I>P.T	A 相电流 Ia	浮点数 Float	A
		B 相电流 Ib	浮点数 Float	A
		C 相电流 Ic	浮点数 Float	A
15	重合闸 [Auto-recloser] Reclose	——	——	——
16	低频减载 [Under Frequency] UnderFr.	频率 Frequency	浮点数 Float	Hz
17	手动合闸 [ManualClose]	——	——	——
18	手动分闸 [ManualTrip]	——	——	——
19	过负荷跳闸 I>Lo.T [OverLoadTrip]	最大相电流 Maximum current Im	浮点数 Float	A
20	负序过流一段保护 [Negative sequence Instantaneous overcurrent] I2>>>	负序电流 Negative sequence current I2	浮点数 Float	A
		最大相电流 Maximum current Im	浮点数 Float	A
21	负序反时限保护 [Negative sequence Inverse Definite Minimum Time] overcurrent I2>InverseT	时间 t	浮点数 Float	s
		负序电流 Negative sequence current I2	浮点数 Float	A
22	热过载跳闸 [Thermal overload Trip] OverHeat.T	跳闸百分比 Trip Percent	浮点数 Float	%
		最大相电流 Maximum current Im	浮点数 Float	A
		正序电流 Positive sequence current I1	浮点数 Float	A
		负序电流 Negative sequence	浮点数 Float	A

		current I2		
23	堵转保护 [Blocking Rotor StallTrip]	最大相电流 Maximum current Im	浮点数 Float	A
24	启动时间过长保护 [Starting time-out] StartOutTime	最大相电流 Maximum current Im	浮点数 Float	A
25	低电压保护 [Under Voltage Trip] LVP.T	最大线电压 Maximum voltage Um	浮点数 Float	V
26	欠电压保护 [Under Voltage Trip] LVP.T	UAB	浮点数 Float	V
		UBC	浮点数 Float	V
		UCA	浮点数 Float	V
27	过电压保护 [Over Voltage Trip] OVP.T	UAB	浮点数 Float	V
		UBC	浮点数 Float	V
		UCA	浮点数 Float	V
28	零序过电压保护/自产零序过 压保护 [Residual Over Voltage Trip/Self-produced Residual Over Voltage Trip] U0.OVP/3U0.OVP	零序电压 Residual voltage U0	浮点数 Float	V
29	不平衡电压保护 [Unbalance Voltage Trip] Unb.V.T	不平衡 U Unbalance Voltage Unb.V	浮点数 Float	V
30	不平衡电流保护 [Unbalance Current Trip] Unb.I.T	不平衡 I Unbalance Current Unb.I	浮点数 Float	A
31	重瓦斯跳闸 [Severe Gas Trip] SevereGas.T	——	——	——
32	压力释放跳闸 [Pressure Release Trip] Pre.Re.T	——	——	——
33	超温跳闸 [High Temperature Trip] HighTemp.T	——	——	——

34	非电量 1 跳闸/计量门 1 跳闸 [Non-electricity 1 Trip/Meter-door 1 Trip] Non-el1.T/Me.do1.T	—	—	—
35	非电量 2 跳闸/计量门 2 跳闸 [Non-electricity 2 Trip/Meter-door 2 Trip] Non-el2.T/Me.do2.T	—	—	—
36	分段备投合母联 [Bus Standby Power Automatic Switch Close Bus] B.S.C.B.	—	—	—
37	分段备投跳进线 1 [Bus Standby Power Automatic Switch Trip 1 Incoming] B.S.T.1	—	—	—
38	分段备投跳进线 2 [Bus Standby Power Automatic Switch Trip 2 Incoming] B.S.T.2	—	—	—
39	2 备 1 跳进线 1 [2 Incoming Spare power, 1 Incoming Primary power, trip 1 Incoming] 2S.1T.1-In.	—	—	—
40	2 备 1 合进线 2 [2 Incoming Spare power, 1 Incoming Primary power, close 2 Incoming] 2S.1C.2-In.	—	—	—
41	1 备 2 跳进线 2 [1 Incoming Spare power, 2 Incoming Primary power, trip 2 Incoming] 1S.2T.2-In.	—	—	—
42	1 备 2 合进线 1 [1 Incoming Spare power, 2 Incoming Primary power, close 1 Incoming] 1S.2C.1-In.	—	—	—
43	分段复归合进线 1 [Bus Standby Power	—	—	—

	Automatic Reset Close 1 Incoming] B.R.C.1			
44	分段复归合进线 2 [Bus Standby Power Automatic Reset Close 2 Incoming] B.R.C.2	——	——	——
45	分段复归跳母联 [Bus Standby Power Automatic Reset Trip Bus] B.R.T.B.	——	——	——
46	2 备 1 复归合进线 1 [2 Incoming Spare power, 1 Incoming Primary power, Reset close 1 Incoming] 2S.1R.C.1	——	——	——
47	2 备 1 复归跳进线 2 [2 Incoming Spare power, 1 Incoming Primary power, Reset trip 2 Incoming] 2S.1R.T.2	——	——	——
48	1 备 2 复归合进线 2 [1 Incoming Spare power, 2 Incoming Primary power, Reset close 2 Incoming] 1S.2R.C.2	——	——	——
49	1 备 2 复归跳进线 1 [1 Incoming Spare power, 2 Incoming Primary power, Reset trip 1 Incoming] 1S.2R.T.1	——	——	——
50	FC 闭锁 [FC Block]	A 相电流 Ia	浮点数 Float	A
		B 相电流 Ib	浮点数 Float	A
		C 相电流 Ic	浮点数 Float	A
51	变压器门误开跳闸 [Transformer Door Open Trip] DoorOpenT	——	——	——
52	遥控合闸 [RemoteClose]	——	——	——
53	遥控分闸	——	——	——

	[RemoteTrip]			
54	失压保护 [Loss of Voltage Trip] LVP.T	最大线电压 Maximum voltage Um	浮点数 Float	V
55	油位低跳闸 [Low oil Trip] Low oil.T	——	——	——
56	油位高跳闸 [High oil Trip] High oil.T	——	——	——
57	反时限过流保护 [Inverse Definite Time overcurrent] I>InverseT.	时间 t	浮点数 Float	s
		A 相电流 Ia	浮点数 Float	A
		B 相电流 Ib	浮点数 Float	A
		C 相电流 Ic	浮点数 Float	A
58	I01 过流三段 [I01 ground fault Definite time overcurrent] I01>	I01	浮点数 Float	A
59	I01 后加速过流 [I01 ground fault Post-accelerated overcurrent] I01>P.T	时间 t	浮点数 Float	s
		I01	浮点数 Float	A
60	高温保护跳闸 [Over Temperature Trip] OverTemp.T	——	——	——
61	轻瓦斯保护跳闸 [Light Gas Trip] LightGasT	——	——	——
62	2 备 1 跳母联 [2 Incoming Spare power, 1 Incoming Primary power, trip bus] 2S.1T.B.	——	——	——
63	2 备 1 复归合母联 [2 Incoming Spare power, 1 Incoming Primary power, Reset close bus] 2S.1R.C.B.	——	——	——
64	柴发机备投跳进线 1	——	——	——

	[Diesel Generator Standby Power Automatic Switch Trip 1 Incoming] Die.S.T.1			
65	柴发机备投跳进线 2 [Diesel Generator Standby Power Automatic Switch Trip 2 Incoming] Die.S.T.2	——	——	——
66	柴发机备投合母联 [Diesel Generator Standby Power Automatic Switch Close Bus] Die.S.C.B.	——	——	——
67	柴发机备投合柴发机 [Diesel Generator Standby Power Automatic Switch Close Diesel Gnerator] Die.S.C.D.	——	——	——
68	非电量 3 跳闸 [Non-electricity 3 Trip] Non-el3.T	——	——	——
69	非电量 4 跳闸 [Non-electricity 4 Trip] Non-el4.T	——	——	——
70	备用 1 跳闸 [Spare 1 Trip] Spare1.T	——	——	——
71	备用 2 跳闸 [Spare 2 Trip] Spare2.T	——	——	——
73	备用 3 跳闸 [Spare 3 Trip] Spare3.T	——	——	——
74	隔离柜连跳 [Isolation Intertrip] Iso.Cab.T	——	——	——
75	系统谐振跳闸 [System Resonanc Trip] Sys.Res.T	——	——	——
76	高频保护 [Over Frequency] OF.T	频率 Frequency	浮点数 Float	Hz

77	温控器故障跳闸 [Temperature Controller Failure Trip] Th.Fa.T	——	——	——
78	自产 3I0 保护一段跳闸 [Self-produce ground fault Instantaneous overcurrent] 3I0>>>	A 相电流 Ia	浮点数 Float	A
		B 相电流 Ib	浮点数 Float	A
		C 相电流 Ic	浮点数 Float	A
		3I0	浮点数 Float	A
79	自产 3I0 保护二段跳闸 [Self-produce ground fault Time-limited overcurrent] 3I0>>	A 相电流 Ia	浮点数 Float	A
		B 相电流 Ib	浮点数 Float	A
		C 相电流 Ic	浮点数 Float	A
		3I0	浮点数 Float	A
80	过负荷告警 I>Lo.A [Over Load Alarm] OverLoadAla.	最大相电流 Maximum current Im	浮点数 Float	A
81	PT 断线告警 (AM5、AM4-U) [PT Break Alarm] PT BreakAla.	UAB	浮点数 Float	V
		UBC	浮点数 Float	V
		UCA	浮点数 Float	V
		负序电压 Negative sequence voltage U2	浮点数 Float	V
82	控故障告警 [Control Circuit Break Alarm] CtrErrorAla.	——	——	——
83	负序过流二段告警 [Negative sequence Time-limited overcurrent Alarm] I2>>.A	负序电流 I2	浮点数 Float	A
		最大相电流 Maximum current Im	浮点数 Float	A

84	热过载告警 [Thermal overload Alarm] OverHeat.A	告警百分比 Alarm percent	浮点数 Float	%
		最大相电流 Maximum current Im	浮点数 Float	A
		正序电流 Positive sequence current I1	浮点数 Float	A
		负序电流 Negative sequence current I2	浮点数 Float	A
85	I母低电压告警 LVP.A (AM5\AM4-U1) [I Bus Under Voltage Alarm] I Bus LVP.A	最大线电压 Maximum voltage Um	浮点数 Float	V
86	I母过电压告警 (AM5\AM4-U1) [I Bus Over Voltage Alarm] I Bus OVP.A	最大线电压 Maximum voltage Um	浮点数 Float	V
87	I母零序过压告警 (AM5\AM4-U1) [I Bus Residual Over Voltage] Alarm I Bus U0.OVP.A	零序电压 Residual Voltage U0	浮点数 Float	V
88	轻瓦斯告警 [Light Gas Alarm] LightGasA			
89	高温告警 [Over Temperature Alarm] OverTemp.A			
90	非电量 2 告警 [Non-electricity 2 Alarm] Non-el2.A	——	——	——
91	非电量 3 告警 [Non-electricity 3 Alarm] Non-el3.A	——	——	——
92	分段充电完成 [BusCharge]	——	——	——
93	进线 1 充电完成 [1 In-coming Charge] I-In.Charge	——	——	——

94	进线 2 充电完成 [2 In-coming Charge 2-In.Charge]	——	——	——
95	I母自产零序过压告警 (AM5\AM4-U1) [I Bus Self-produced Residual Over Voltage Alarm] I Bus 3U0.OVP.A	零序电压 Residual Voltage U0	浮点数 Float	V
96	II母低电压告警 (AM5\AM4-U2) [II Bus Under Voltage Alarm] II Bus LVP.A	最大线电压 Maximum voltage Um	浮点数 Float	V
97	II母零序过压告警 (AM5\AM4-U2) [II Bus Residual Over Voltage Alarm] II Bus U0.OVP.A	零序电压 Residual Voltage U0	浮点数 Float	V
98	II母 PT 断线告警 (AM5\AM4-U2) [II Bus PT Break Alarm] II Bus PT BreakAla.	UAB2	浮点数 Float	V
		UBC2	浮点数 Float	V
		UCA2	浮点数 Float	V
		负序电压 Negative sequence voltage U2	浮点数 Float	V
99	II母过电压告警 (AM5\AM4-U2) [II Bus Over Voltage Alarm] II Bus OVP.A	最大线电压 Maximum voltage Um	浮点数 Float	V
100	II母自产零序过压告警 (AM5\AM4-U2) [II Bus Self-produced Residual Over Voltage Alarm] II Bus 3U0.OVP.A	零序电压 Residual Voltage U0	浮点数 Float	V
101	电机备投跳进线 1,2 [Motor Standby Power Automatic Switch Trip 1,2 Incoming] M.S.T.1,2	——	——	——
102	电机备投合电机 [Motor Standby Power Automatic Switch Close]	——	——	——

	Motor] M.S.C.M.			
103	过流三段告警 [Definite time overcurrent Alarm] 3I>.A	A 相电流 Ia	浮点数 Float	A
		B 相电流 Ib	浮点数 Float	A
		C 相电流 Ic	浮点数 Float	A
104	I01 过流一段告警 [I01 ground fault Instantaneous overcurrent Alarm] I01>>>.A	时间 t	浮点数 Float	s
		I01	浮点数 Float	A
105	I01 过流二段告警 [I01 ground fault Time-limited overcurrent Alarm] I01>>.A	时间 t	浮点数 Float	s
		I01	浮点数 Float	A
106	I01 过流三段告警 [I01 ground fault Definite time overcurrent Alarm] I01>.A	时间 t	浮点数 Float	s
		I01	浮点数 Float	A
107	I01 反时限过流告警 [I01 ground fault Inverse Definite Minimum Time overcurrent Alarm] I01>InverseT.A	时间 t	浮点数 Float	s
		I01	浮点数 Float	A
108	I01 后加速告警 [I01 ground fault Post-accelerated overcurrent Alarm] I01>P.A	时间 t	浮点数 Float	s
		I01	浮点数 Float	A
109	I02 过流告警 [I02 ground fault overcurrent Alarm] I02>.A	时间 t	浮点数 Float	s
		I02	浮点数 Float	A
110	I02 反时限过流告警 [I02 ground fault Inverse Definite Time overcurrent Alarm]	时间 t	浮点数 Float	s
		I02	浮点数 Float	A

	I02>Inverse T.A			
111	负序过流一段告警 [Negative sequence Instantaneous overcurrent Alarm] I2>>>.A	负序电流 Negative sequenc current I2	浮点数 Float	A
		最大相电流 Maximum current Im	浮点数 Float	A
112	超温保护告警 [High Temperature Alarm] HighTemp.A			
113	重瓦斯保护告警 [Severe Gas Alarm] SevereGas.A			
114	失压告警 [Loss of Voltage Alarm] LVP.A	最大线电压 Maximum voltage Um	浮点数 Float	V
115	I02 过流一段告警 [I02 ground fault Instantaneous overcurrent Alarm] I02>>>.A	时间 t	浮点数 Float	s
		I02	浮点数 Float	A
116	I02 过流二段告警 段告警 [I02 ground fault Time-limited overcurrent Alarm] I02>>.A	时间 t	浮点数 Float	s
		I02	浮点数 Float	A
117	门开告警 [Transformer Door Alarm] DoorOpenA	时间 t	浮点数 Float	s
118	进线 PT 断线 [In-coming PT Break Alarm] I.PtBr.A	——	——	——
119	非电量 1 告警 [Non-electricity 1 Alarm] Non-el1.A			s
120	非电量 4 告警 [Non-electricity 4 Alarm] Non-el4.A			s
121	重合闸充电完成 [Auto-reclose Charge] chargeOK	——	——	——

122	备用 1 告警 [Spare 1 Alarm] Spare1.A	—	—	—
123	备用 2 告警 [Spare 2 Alarm] Spare2.A	—	—	—
124	备用 3 告警 [Spare 3 Alarm] Spare3.A	—	—	—
125	市电充电 [Power Supply Charge] Mark.Charge	—	—	—
126	市电备投跳发电机 [Power Supply Standby Power Automatic Switch Trip Generator] Mark.S.T.D.	—	—	—
127	市电备投合进线 1 [Power Supply Standby Power Automatic Switch Close 1 In-coming] Mark.S.C.1	—	—	—
128	市电备投合进线 2 [Power Supply Standby Power Automatic Switch Close 2 In-coming] Mark.S.C.2	—	—	—
129	逆功率保护 [Reverse Power Trip] R.P.T	有功功率 Active power	浮点数 Float	kW
		功率因数 Power factor	浮点数 Float	
130	压力释放告警 [Pressure Release Alarm] Pre.Re.A	—	—	—
131	发电机备 1 充电 [Generator Spare power, 1 In-coming Primary power Charge] A1.S.1.Charge	—	—	—
132	发电机备 2 充电 [Generator Spare power, 2 In-coming Primary power Charge] A1.S.2.Charge	—	—	—

133	柴发机备 1 跳 1QF [Diesel Generator Spare power, 1 In-coming Primary, Trip 1QF] Die.S.1T.1QF	——	——	——
134	柴发机备 1 合 4QF [Diesel Generator Spare power, 1 In-coming Primary, Close 4QF] Die.S.1C.4QF	——	——	——
135	柴发机备 2 跳 2QF [Diesel Generator Spare power, 2 In-coming Primary, Trip 2QF] Die.S.2T.2QF	——	——	——
136	柴发机备 2 合 4QF [Diesel Generator Spare power, 2 In-coming Primary, Close 4QF] Die.S.2C.4QF	——	——	——
137	温控器故障告警 [Temperature Controller Failure Alarm] Th.Fa.A	——	——	——
138	二次过压告警（非电量） [Secondary Over Voltage Alarm] Se.OVP.A	——	——	——
139	不平衡电流 3I0 保护告警 [Unbalance Current Alarm] Unb.3I0.A	A 相电流 Ia	浮点数 Float	A
		B 相电流 Ib	浮点数 Float	A
		C 相电流 Ic	浮点数 Float	A
		3I0	浮点数 Float	A
150	DI1 变位 [DI1 Set] DI1	——	——	——
151	DI2 变位 [DI2 Set] DI2	——	——	——
152	DI3 变位	——	——	——

	[DI3 Set] DI3			
153	DI4 变位 [DI4 Set] DI4	—	—	—
154	DI5 变位 [DI5 Set] DI5	—	—	—
155	DI6 变位 [DI6 Set] DI6	—	—	—
156	DI7 变位 [DI7 Set] DI7	—	—	—
157	DI8 变位 [DI8 Set] DI8	—	—	—
158	DI9 变位 [DI9 Set] DI9	—	—	—
159	DI10 变位 [DI10 Set] DI10	—	—	—
160	DI11 变位 [DI11 Set] DI11	—	—	—
161	DI12 变位 [DI12 Set] DI12	—	—	—
162	DI13 变位 [DI13 Set] DI13	—	—	—
163	DI14 变位 [DI14 Set] DI14	—	—	—
164	DI15 变位 [DI15 Set] DI15	—	—	—
165	DI16 变位 [DI16 Set] DI16	—	—	—
166	DI17 变位 [DI17 Set] DI17	—	—	—

167	DI18 变位 [DI18 Set] DI18	—	—	—
168	DI19 变位 [DI19 Set] DI19	—	—	—
169	DI20 变位 [DI20 Set] DI20	—	—	—
170	合后位置变位 [Position after closing set]	—	—	—
171	合位监视变位 [Circuit Breaker On Set] CCB On set	—	—	—
172	分位监视变位 [Circuit Breaker Off Set] CCB Off set	—	—	—
173	防跳监视变位 [Anti-pumping set]	—	—	—
174	装置上电 [Device on power]	—	—	—
179	PT 断线 [PT Break]	—	—	—
180	3 备 1 充电 [3 In-coming Spare power, 1 In-coming Primary power Charge] 3S.1 Charge	—	—	—
181	3 备 2 充电 [3 In-coming Spare power, 2 In-coming Primary power Charge] 3S.2 Charge	—	—	—
182	A 相差压跳闸 [Phase A Differential Voltage Trip] UdA.T	A 相差压 Phase A Differential Voltage UdA	浮点数 Float	V
183	B 相差压跳闸 [Phase B Differential Voltage] UdB.T	B 相差压 Phase B Differential Voltage UdB	浮点数 Float	V
184	C 相差压跳闸 [Phase C Differential Voltage]	C 相差压 Phase C Differential	浮点数 Float	V

	UdC.T	Voltage UdC		
185	备投再恢复 1#合 3QF [Standby Power Automatic Switch Reset 1#, Close 3QF] S.R.1#.C.3QF	—	—	—
186	均无压恢复充电 [Loss of Voltage Reset Charge] No-Vol.R.Charge	—	—	—
187	均无压复 2 跳 4 [Loss of Voltage Reset 2 In-coming Trip 4 In-coming] No-Vol.R.2.T.4	—	—	—
188	均无压复 2 合 2 [Loss of Voltage Reset 2 In-coming Close 4 In-coming] No-Vol.R.2.C.2	—	—	—
189	均无压复 1 跳 4 [Loss of Voltage Reset 1 In-coming Trip 4 In-coming] No-Vol.R.1.T.4	—	—	—
190	均无压复 1 合 1 [Loss of Voltage Reset 1 In-coming Close 1 In-coming] No-Vol.R.1.C.1	—	—	—
191	均无压复 1 合 3 [Loss of Voltage Reset 1 In-coming Close 3 In-coming] No-Vol.R.1.C.3	—	—	—
192	远方按钮合闸 [Remote button close]	—	—	—
193	远方按钮分闸 [Remote button trip]	—	—	—
194	急停分闸 [Emergency trip]	—	—	—
195	2 备 1 合柴发 [2 In-coming Spare power, 1 In-coming Primary power, Close Diesel Generator] 2S.1C.Die.	—	—	—
196	2 备 1 复归跳柴发 [2 In-coming Spare power, 1 In-coming Primary power, Reset Trip Diesel Generator]	—	—	—

	2S.1R.T.Die.			
197	负控跳闸 [Load Control Trip] Neg.Con.T	—	—	—
198	绝缘监测告警 [Residual Monitor Alarm] Insul.Monit.A	—	—	—
199	绝缘监测跳闸 [Residual Monitor Trip] Insul.Monit.T	—	—	—
200	均无压充电 [Loss of Voltage Charge] No-Vol.Charge	—	—	—
201	均无压跳 2 [Loss of Voltage Trip 2 In-coming] No-Vol.T.2	—	—	—
202	均无压合 1 [Loss of Voltage Close 1 In-coming] No-Vol.C.1	—	—	—
203	备用进线备 1 充电 [Spare In-coming Standby Power Automatic Switch 1 In-coming Charge] Sp.In.S1 Charge	—	—	—
204	备用进线备 2 充电 [Spare In-coming Standby Power Automatic Switch 2 In-coming Charge] Sp.In.S2 Charge	—	—	—
205	备用进线备 1 跳进线 1 [Spare In-coming Standby Power Automatic Switch 1 In-coming Trip 1 In-coming] Sp.In.S1.T.1	—	—	—
206	备用进线备 1 合备用 [Spare In-coming Standby Power Automatic Switch 1 In-coming Close Spare In-coming] Sp.In.S1.C.Sp.	—	—	—
207	备用进线备 2 跳进线 2 [Spare In-coming Standby	—	—	—

	Power Automatic Switch 2 In-coming Trip 2 In-coming] Sp.In.S2.T.2			
208	备用进线备 2 合备用 [Spare In-coming Standby Power Automatic Switch 2 In-coming Close Spare In-coming] Sp.In.S2.C.Sp	—	—	—
209	均无压跳进线 1,2 [Loss of Voltage Trip 1,2 In-coming] No-Vol.T.1,2	—	—	—
210	均无压合母联 [Loss of Voltage Close Bus] No-Vol.C.B.	—	—	—
211	均无压合备用进线 [Loss of Voltage Close Spare In-coming] No-Vol.C.Sp.In.	—	—	—
212	欠流告警 [Under Current Alarm] LIP.A	A 相电流 Ia	浮点数 Float	A
		B 相电流 Ib	浮点数 Float	A
		C 相电流 Ic	浮点数 Float	A
213	电压不平衡开入跳闸 [Unbalance Voltage Trip] Unb.V.DI.T	—	—	—
214	分段备投合进线 3 [Bus Standby Power Automatic Switch Close 3 In-coming] B.S.C.3	—	—	—
215	分段备投合进线 4 [Bus Standby Power Automatic Switch Close 4 In-coming] B.S.C.4	—	—	—
216	进线 1 逆功率 [1 In-coming Reverse Power Trip] 1-In.RP.T	—	—	—
217	2 备 1 跳进线 1 手车	—	—	—

	[2 In-coming Spare power, 1 In-coming Primary power, trip 1 In-coming Handcart] 2S.1T.1-In.Hand.			
218	2 备 1 复归合进线 1 手车 [2 In-coming Spare power, 1 In-coming Primary power, Reset Close 1 In-coming Handcart] 2S.1R.C.1-In.Hand.	—	—	—
219	低侧网门告警 [Low side net-door Alarm] Low S.D.A	—	—	—
220	低侧网门跳闸 [Low side net-door Trip] Low S.D.T	—	—	—
221	事故总信号 [Accident Signal]	—	—	—
222	电压不平衡跳闸 [Unbalance Voltage Trip] Unb.V.T	—	—	—
223	相序保护跳闸 [Incorrect Phase Sequence Voltage Trip] Ph.Se.T	—	—	—
224	断相保护跳闸 [Voltage Phase Loss Trip] Break ph.T	—	—	—
225	I段 PT 投入 [I Bus PT Input] I PT Invest.	—	—	—
226	II段 PT 投入 [II Bus PT Input] II PT Invest.	—	—	—
227	PT 并列 [PT Parallel] PT Juxtaposition	—	—	—
228	1 号 2 号主供断电警报 [1,2 In-coming Primary power loss Alarm] 1,2 Main supply outage.A	—	—	—
229	遥控并列 [Remote Parallel] Remote Juxtaposition	—	—	—

230	遥控解列 [Remote Disconnection] Remote Splitting	——	——	——
231	母线充电保护 [Bus Charge Trip] B.Cha.T	A 相电流 Ia	浮点数 Float	A
		B 相电流 Ib	浮点数 Float	A
		C 相电流 Ic	浮点数 Float	A
232	CT 二次过压跳闸 [Secondary CT Over Voltage Trip] CT Se.OVP.T	——	——	——
233	CT 二次过压告警 [Secondary CT Over Voltage Alarm] CT Se.OVP.A	——	——	——
234	隔离手车连跳动作 [Isolation Handcart Intertrip] Iso.Handcart.T	——	——	——
235	备投允许 [Standby Power Automatic Switch Permission] Standby allowed	——	——	——
236	允许合闸信号 [Close Circuit Breaker Signal Permission] Allowable C.signal	——	——	——
237	柴发机备投跳母联 [Diesel Generator Standby Power Automatic Switch Trip Bus] Die.S.T.B.			
238	备投启动柴发信号 [Standby Power Automatic Switch Start Diesel Generator Signal] S.Sta.Die.Sig.			
239	油位高告警 [High oil Alarm] High oil.A			
240	均无压跳母联 [Loss of Voltage Trip Bus] No-Vol.T.B.			

241	负序过流二段跳闸 [Negative sequence Time-limited overcurrent] I2>>	负序电流 I2	浮点数 Float	A
		最大相电流 Maximum Current Im	浮点数 Float	A
242	差动总启动标志 [Differential total start flag]	——	——	——
243	差动速断保护 [Instantaneous Differential Differential quick break protection]	动作时间 Action time	浮点数 Float	s
		A 相差流 Differential IA IdA	浮点数 Float	A
		B 相差流 Differential IB IdB	浮点数 Float	A
		C 相差流 Differential IC IdC	浮点数 Float	A
		A 相制动 Restraint IA IrA	浮点数 Float	A
		B 相制动 Restraint IB IrB	浮点数 Float	A
		C 相制动 Restraint IC IrC	浮点数 Float	A
244	比率差动保护 [Differential protection with Ratio Restraining] Ratio differential protection	动作时间 Action time	浮点数 Float	s
		A 相差流 Differential IA IdA	浮点数 Float	A
		B 相差流 Differential IB IdB	浮点数 Float	A
		C 相差流 Differential IC IdC	浮点数 Float	A
		A 相制动 Restraint IA IrA	浮点数 Float	A
		B 相制动 Restraint IB IrB	浮点数 Float	A

		C相制动 Restraint IC IrC	浮点数 Float	A
245	差流越限 [Differential current overshoot]	A相差流 Differential IA IdA	浮点数 Float	A
		B相差流 Differential IB IdB	浮点数 Float	A
		C相差流 Differential IC IdC	浮点数 Float	A
246	正序过流一段保护 [Positive sequence Instantaneous overcurrent] I1>>>	定值 Fixed value	浮点数 Float	A
		延时 Delayed	浮点数 Float	s
		正序电流 Positive sequence current I1	浮点数 Float	A
247	正序过流二段保护 [Positive sequence Time-limited overcurrent] I1>>	定值 Fixed value	浮点数 Float	A
		延时 Delayed	浮点数 Float	s
		正序电流 Positive sequence current I1	浮点数 Float	A
248	正序过流反时限保护 [Positive sequence Inverse Definite Time overcurrent] I1>InverseT.	曲线类型 Curve type	整数 Integer	一般/非常/ 极端 S1/S2/S3
		启动电流 Starting current	浮点数 Float	A
		时间系数 Time coefficient	浮点数 Float	s
		动作时间 Action time	浮点数 Float	s
		正序电流 Positive sequence current I1	浮点数 Float	A
249	长启动保护告警 [Starting time-out Alarm Long start protection alarm]	计时门槛 Timing threshold	浮点数 Float	A
		动作时间	浮点数	s

		Action time	Float	
250	电流不平衡告警 [Unbalance current Alarm] Unb.I.A	定值 Fixed value	浮点数 Float	A
		延时 Delayed	浮点数 Float	s
		动作值 Action value	浮点数 Float	A
		平均电流 Iavg	浮点数 Float	A
251	电压不平衡告警 [Unbalance Voltage Alarm] Unb.V.A	定值 Fixed value	浮点数 Float	V
		延时 Delayed	浮点数 Float	s
		动作值 Action value	浮点数 Float	V
		平均线电压 Average Voltage Uavg	浮点数 Float	V
		UAB	浮点数 Float	V
		UBC	浮点数 Float	V
		UCA	浮点数 Float	V
252	过电压保护告警 [Over Voltage Alarm] OVP.A	定值 Fixed value	浮点数 Float	V
		延时 Delayed	浮点数 Float	s
		UAB	浮点数 Float	V
		UBC	浮点数 Float	V
		UCA	浮点数 Float	V
		零序电压 Residual Voltage U0	浮点数 Float	V
253	零序过压保护告警 [Residual Over Voltage Alarm] U0.OVP.A	定值 Fixed value	浮点数 Float	V
		延时 Delayed	浮点数 Float	s
		UAB	浮点数 Float	V

		UBC	浮点数 Float	V
		UCA	浮点数 Float	V
		零序电压 Residual Voltage U0	浮点数 Float	V
254	正序过压保护告警 [Positive Over Voltage Alarm] U1.OVPA	定值 Fixed value	浮点数 Float	V
		延时 Delayed	浮点数 Float	s
		UAB	浮点数 Float	V
		UBC	浮点数 Float	V
		UCA	浮点数 Float	V
		正序电压 Positive Voltage U1	浮点数 Float	V
255	正序过压保护跳闸 [Positive Over Voltage Trip] U1.OVP.T	定值 Fixed value	浮点数 Float	V
		延时 Delayed	浮点数 Float	s
		UAB	浮点数 Float	V
		UBC	浮点数 Float	V
		UCA	浮点数 Float	V
		正序电压 Positive Voltage U1	浮点数 Float	V
256	负序过压保护告警 [Negative Over Voltage Alarm] U2.OVPA	定值 Fixed value	浮点数 Float	V
		延时 Delayed	浮点数 Float	s
		UAB	浮点数 Float	V
		UBC	浮点数 Float	V
		UCA	浮点数 Float	V

		负序电压 Negative Voltage U2	浮点数 Float	V
257	负序过压保护跳闸 [Negative Over Voltage Trip] U2.OVP.T	定值 Fixed value	浮点数 Float	V
		延时 Delayed	浮点数 Float	s
		UAB	浮点数 Float	V
		UBC	浮点数 Float	V
		UCA	浮点数 Float	V
		负序电压 Negative Voltage U2	浮点数 Float	V
258	低电压保护告警 [Under Voltage Alarm] LVPA	定值 Fixed value	浮点数 Float	V
		延时 Delayed	浮点数 Float	s
		UAB	浮点数 Float	V
		UBC	浮点数 Float	V
		UCA	浮点数 Float	V
		零序电压 Residual Voltage U0	浮点数 Float	V
259	相序保护告警 [Incorrect Phase Sequence Voltage Alarm] Ph.Se.A	延时 Delayed	浮点数 Float	s
		UAB	浮点数 Float	V
		UBC	浮点数 Float	V
		UCA	浮点数 Float	V
		零序电压 Residual Voltage U0	浮点数 Float	V
		正序电压 Positive Voltage U1	浮点数 Float	V

		负序电压 Negative Voltage U2	浮点数 Float	V
		平均线电压 Average Voltage Uavg	浮点数 Float	V
260	首端 CT 断线告警 [I CT Break Alarm] F.CT Break.A	——	——	——
261	尾端 CT 断线告警 [II CT Break Alarm] T.CT Break.A	——	——	——
262	I02 后加速过流 [I02 ground fault Post-acceleration overcurrent] I02>P.T	时间 t	浮点数 Float	s
		I02	浮点数 Float	A
263	I02 后加速告警 [I02 ground fault Post-acceleration overcurrent Alarm] I02>P.A	时间 t	浮点数 Float	s
		I02	浮点数 Float	A
264	差动保护长期启动 [Long term start of differential protection]	A 相差流 Differential IA IdA	浮点数 Float	A
		B 相差流 Differential IB IdB	浮点数 Float	A
		C 相差流 Differential IC IdC	浮点数 Float	A
265				
266				
267	I侧 CT 断线告警 [I CT Break Alarm] I CT Break.A	——	——	——
268	II侧 CT 断线告警 [II CT Break Alarm] II CT Break.A	——	——	——

269	III侧 CT 断线告警 [III CT Break Alarm] III CT Break.A	——	——	——
270	IV侧 CT 断线告警 [IV CT Break Alarm] IV CT Break.A	——	——	——
271	有压有流出口动作 [Voltage and current trip Pressure and current outlet action]	——	——	——
272	预留 (告警事件代码)			
289		Reserve		
290	启动风冷 [Start air-cooled water chiller]	A 相电流 Ia	浮点数 Float	A
		B 相电流 Ib	浮点数 Float	A
		C 相电流 Ic	浮点数 Float	A
291	闭锁调压 [Blocking voltage regulation]	A 相电流 Ia	浮点数 Float	A
		B 相电流 Ib	浮点数 Float	A
		C 相电流 Ic	浮点数 Float	A
292	间隙零序过流一段跳闸 [Transient ground fault Instantaneous overcurrent] Clearance I0>>>	间隙零序电流 Transient ground fault current Clearance I0	浮点数 Float	A
293	间隙零序过流二段跳闸 [Transient ground fault Time-limited overcurrent] Clearance I0>>	间隙零序电流 Transient ground fault current Clearance I0	浮点数 Float	A
294	I段 PT 投入 [I Bus PT Input] I PT Invest.	——	——	——
295	II段 PT 投入 [II Bus PT Input] II PT Invest.	——	——	——
296	PT 自动并列 [PT auto-Parallel] PT Juxtaposition	——	——	——
297	遥控并列	——	——	——

	[Remote Parallel] Remote Juxtaposition			
298	遥控解列 [Remote Disconnection] Remote Splitting	——	——	——
299	负控保护跳闸 [Load Control Trip] Neg.Con.T	时间 t	浮点数 Float	s
300	负控保护告警 [Load Control Alarm] Neg.Con.A	时间 t	浮点数 Float	s
301	PT 自动解列 [PT Disconnection] PT Splitting	——	——	——
302	二次谐波闭锁 [Second Harmonic Block] SHB.	A 相二次谐波电流 Ia Second Harmonic Ia_H2	浮点数 Float	A
		B 相二次谐波电流 Ib Second Harmonic Ib_H2	浮点数 Float	A
		C 相二次谐波电流 Ic Second Harmonic Ic_H2	浮点数 Float	A
303	1 备 2 跳非重要负荷 [1 In-coming Spare power, 2 In-coming Primary power, trip Unimportant Load] 1S.2T.Unimp.Lo.	——	——	——
304	2 备 1 跳非重要负荷 [2 In-coming Spare power, 1 In-coming Primary power, trip Unimportant Load] 2S.1T.Unimp.Lo.	——	——	——
305	I02 过流三段 [I02 ground fault Definite time overcurrent] I02>	I02	浮点数 Float	A
306	I02 过流三段告警 [I02 ground fault Definite time overcurrent Alarm] I02>.A	I02	浮点数 Float	A
307	检修状态闭锁 [Maintenance Block] Maint.Sta.B.	——	——	——

308	电机温度 1 跳闸 [Motor Temperature 1 Trip] M.Tem1.T	——	——	——
309	电机温度 1 告警 [Motor Temperature 1 Alarm] M.Tem1.A	——	——	——
310	电机温度 2 跳闸 [Motor Temperature 2 Trip] M.Tem2.T	——	——	——
311	电机温度 2 告警 [Motor Temperature 2 Alarm] M.Tem2.A	——	——	——
312	电源监视跳闸 [Power Monitor Trip] Pow.Monit.T	——	——	——
313	电源监视告警 [Power Monitor Alarm] Pow.Monit.A	——	——	——
314	备投停止柴发信号 [Standby Power Automatic Switch Stop Diesel Generator Signal] S.St.Die.Sig.			
315	启动柜故障跳闸 [Starting Cabinet Failure Trip] St.Cab.Fa.T	——	——	——
316	启动柜故障告警 [Starting Cabinet Failure Alarm] St.Cab.Fa.A	——	——	——
317	同期合闸 [Synchronous Close Permission] Synchronous.C	——	——	——
318	进线侧恢复充电 [In-coming Reset Charge] In.R.Charge	——	——	——
319	柴发充电 [Diesel Generator Charge] Die.Charge	——	——	——
320	市电恢复充电 [Power Supply Reset Charge] Mark.R.Charge	——	——	——
321	柴发恢复充电	——	——	——

	[Diesel Generator Reset Charge] Die.R.Charge			
322	柴发备投合柴发 [Diesel Generator Standby Power Automatic Switch Close Diesel Generator] Die.S.C.D.	—	—	—
323	市电恢复跳柴发 [Power Supply Standby Power Automatic Switch Reset Trip Diesel Generator] Mark.R.T.D.	—	—	—
324	市电恢复合市电 [Power Supply Standby Power Automatic Switch Reset Close Power Supply] Mark.R.C.Mark.	—	—	—
325	柴发恢复合柴发 [Diesel Generator Standby Power Automatic Switch Reset Close Diesel Generator] Mark.R.C.D.	—	—	—
326	弧光保护跳闸 [Arc flash Protection Trip] Arc.Pro.T	—	—	—
327	弧光保护告警 [Arc flash Protection Alarm] Arc.Pro.A	—	—	—
328	均无压进线 1 充电 [Loss of Voltage 1 In-coming Charge] No-Vol.1-In.Charge	—	—	—
329	均无压进线 2 充电 [Loss of Voltage 2 In-coming Charge] No-Vol.2-In.Charge	—	—	—
330	均无压合 2 [Loss of Voltage Close 2 In-coming] No-Vol.C.2	—	—	—
331	均无压跳 1 [Loss of Voltage Trip 1	—	—	—

	In-coming] No-Vol.T.1			
332	均无压跳 3 [Loss of Voltage Trip 3 In-coming] No-Vol.T.3	_____	_____	_____
333	A 相二次谐波 [Ia Second Harmonic Block] A.SH.	A 相二次谐波电流 Ia Second Harmonic Ia_H2	浮点数 Float	A
		B 相二次谐波电流 Ib Second Harmonic Ib_H2	浮点数 Float	A
		C 相二次谐波电流 Ic Second Harmonic Ic_H2	浮点数 Float	A
334	B 相二次谐波 [Ib Second Harmonic Block] B.SH.	A 相二次谐波电流 Ia Second Harmonic Ia_H2	浮点数 Float	A
		B 相二次谐波电流 Ib Second Harmonic Ib_H2	浮点数 Float	A
		C 相二次谐波电流 Ic Second Harmonic Ic_H2	浮点数 Float	A
335	C 相二次谐波 [Ic Second Harmonic Block] C.SH.	A 相二次谐波电流 Ia Second Harmonic Ia_H2	浮点数 Float	A
		B 相二次谐波电流 Ib Second Harmonic Ib_H2	浮点数 Float	A
		C 相二次谐波电流 Ic Second Harmonic Ic_H2	浮点数 Float	A

Headquarters: Acrel Co., Ltd.

Trade Company: Acrel E-Business(Shanghai)Co., Ltd.

Address: No.253 Yulv Road, Jiading District, Shanghai, China

TEL.: 0086-21-69156352

Web-site: www.acrel-electric.com

E-mail: sales@acrel-electric.com

Postcode: 201801

Manufacturer: Jiangsu Acrel Electrical Manufacturing Co., Ltd.

Address: No.5 Dongmeng Road, Dongmeng industrial Park, Nanzha Street, Jiangyin City,

Jiangsu Province, China

TEL./Fax: 0086-510-86179970

Web-site: www.jsacrel.com

E-mail: sales@email.acrel.cn

Postcode: 214405